

DOUBLE LAYER ROOF – GLUED SYSTEM, CONCRETE SUPPORTING STRUCTURE
BITUMEN SHEET WATERPROOFING

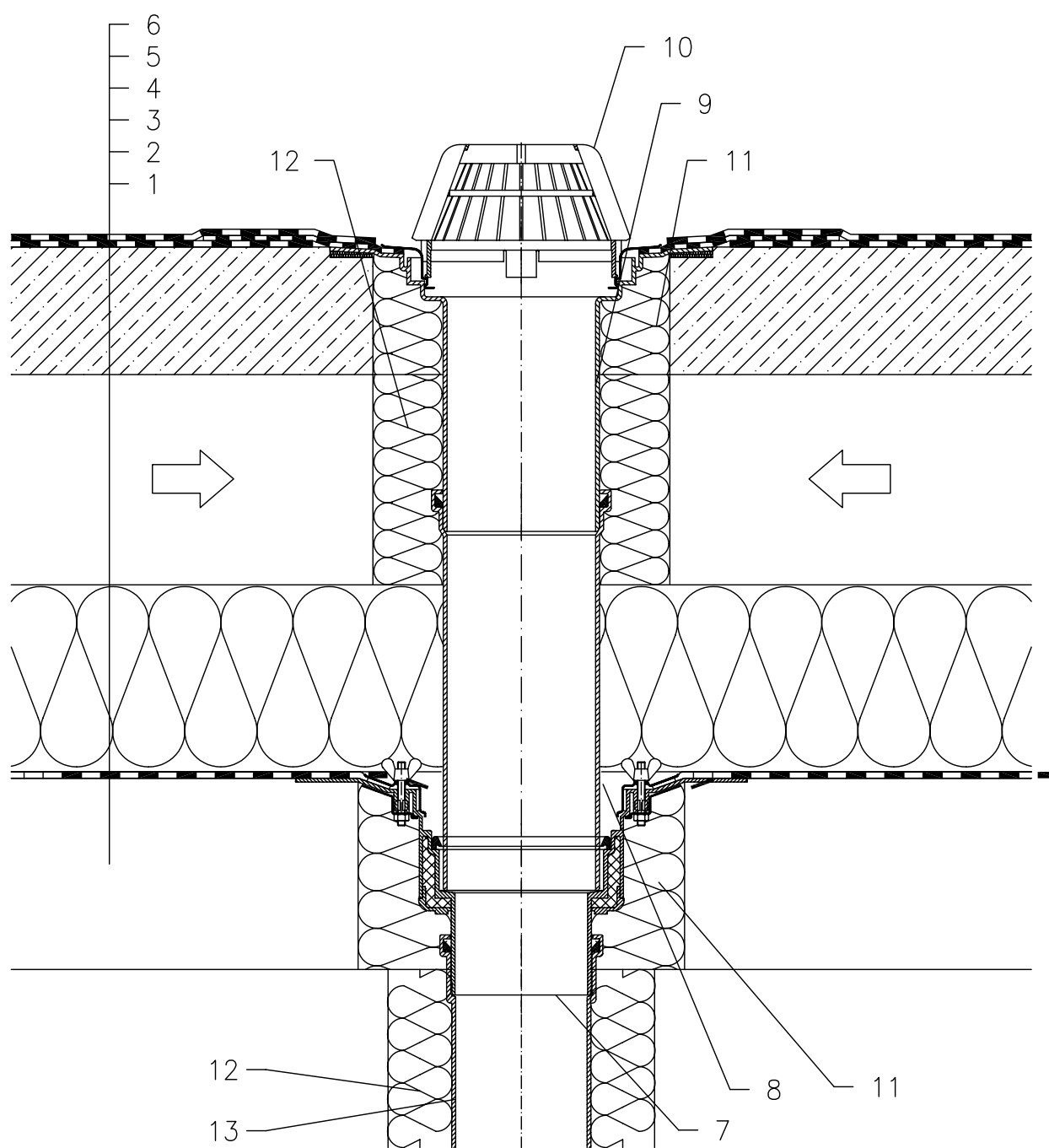

- 1 SUPPORT CONSTRUCTION
- 2 MOISTURE STOP AND TEMPORARY SAFETY WATERPROOFING FROM BITUMEN SHEET OR PLASTIC FOIL
- 3 THERMAL INSULATION
- 4 AIR LAYER
- 5 UPPER CLADDING SUPPORTING STRUCTURE – CONCRETE
- 6 BITUMEN SHEET WATERPROOFING NON-SOLID GLUED
- 7 FLAT-ROOF DRAIN HL62 WITH INSULATED DRAIN BODY, FLANGE WITH STAINLESS STEEL CLAMPING RING
- 8 EXTENSION WITH TUBE DN125
- 9 EXTENSION HL65H WITH FLANGE AND FACTORY WELDED BITUMEN MEMBRANE \varnothing 500 mm, THICKNESS 4 mm
- 10 DOMED PLASTIC GRATE \varnothing 180 mm (INCL. WITH HL62)
- 11 ASSEMBLY FOAM
- 12 DOWNPIPE THERMAL INSULATION
- 13 DOWNPIPE

NOTE:

FLAT-ROOF DRAIN HL62.1 HEATED (230V, 10-30 WATTS) CAN BE USED.

ASSEMBLY INLET: \varnothing 220 MM, ALTERNATIVELY 240X360 MM