

ROOF WITH THERMAL INSULATION – INTENSIVE GRASSING, COMBINED ORDER OF LAYERS  
BITUMEN SHEETS

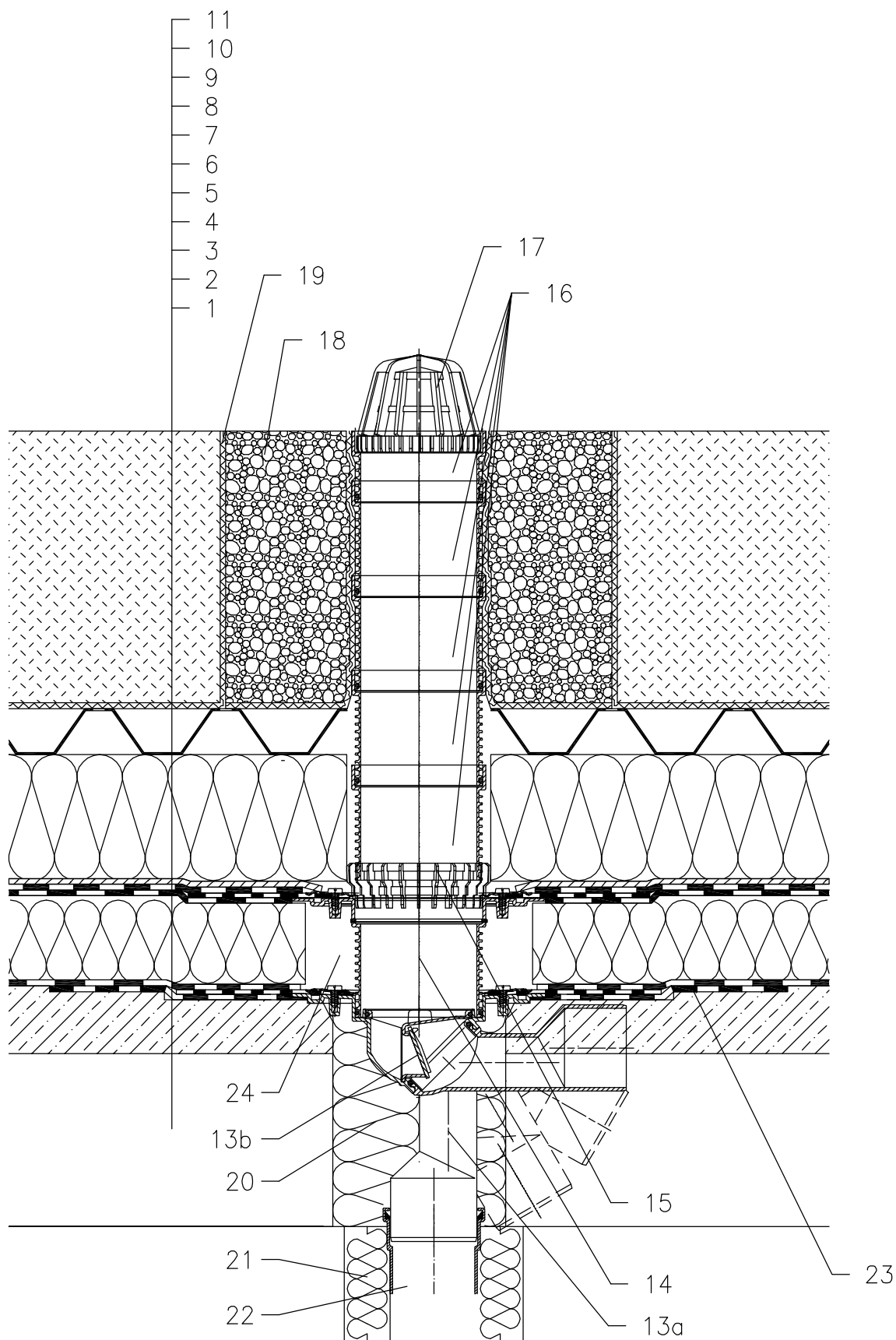

- 1 SUPPORT CONSTRUCTION
- 2 CONCRETE GRAVITY LAYER
- 3 MOISTURE STOP AND TEMPORARY SAFETY WATERPROOFING FROM BITUMEN SHEET
- 4 THERMAL INSULATION
- 5 BITUMEN SHEET WATERPROOFING NON SOLID GLUED OR LAID LOOSE
- 6 BITUMEN SHEET WATERPROOFING
- 7 DRAINAGE LAYER
- 8 XPS THERMAL INSULATION
- 9 WATER ACCUMULATING AND DRAINAGE LAYER
- 10 FILTER LAYER
- 11 VEGETATION LAYER (OVER 200mm)
- 13a ROOF DRAIN HL80.3H WITH BITUMEN MEMBRANE  $\phi$ 400 mm
- 13b FROST-PROOF FLAP HL080.4E (NOT INCLUDED IN HL80.3H)
- 14 EXTENSION HL85NH WITH BITUMEN MEMBRANE  $\phi$ 400 mm; INCL. O-RING (HL340N)
- 15 DRAINAGE RING HL180
- 16 EXTENSION HL340N
- 17 LEAF STRAINER  $\phi$ 110 mm (INCLUDED IN HL80.3H)
- 18 GRANULAR FILL
- 19 SEPARATING LAYER
- 20 ASSEMBLY FOAM
- 21 DOWNPIPE THERMAL INSULATION
- 22 DOWNPIPE
- 23 BITUMEN MEMBRANE  $\phi$ 750 mm
- 24 FILL FREE SPACE WITH MINERAL WOOL

NOTICE:

TO HEAT THE DRAIN, YOU MAY USE HEATING KIT HL82 WITH SELF-REGULATING HEAT SOURCE 18W/220V. (THE HEATING TAPE MUST BE WRAPPED AROUND THE DRAIN BODY BEFORE INSTALLATION).

RECOMMENDED BOREHOLE DIAMETER IS  $\phi$ 150mm.

DURING INSTALLATION TAKE CARE, THAT THE FLANGE POSITION IS ON THE LOWEST LEVEL OF DRAINAGE. WE RECOMMEND, TO SITE IT APPR. 1cm BELOW THE SCREED.

TO AVOID CONDENSATE WATER TAKE CARE OF THERMAL INSULATION ON THE CONSTRUCTION SITE.

142321AX