

ROOF WITH THERMAL INSULATION – CAR PARK, COMBINED ORDER OF LAYERS, COMPACT ROOF VARIANT  
BITUMEN SHEETS

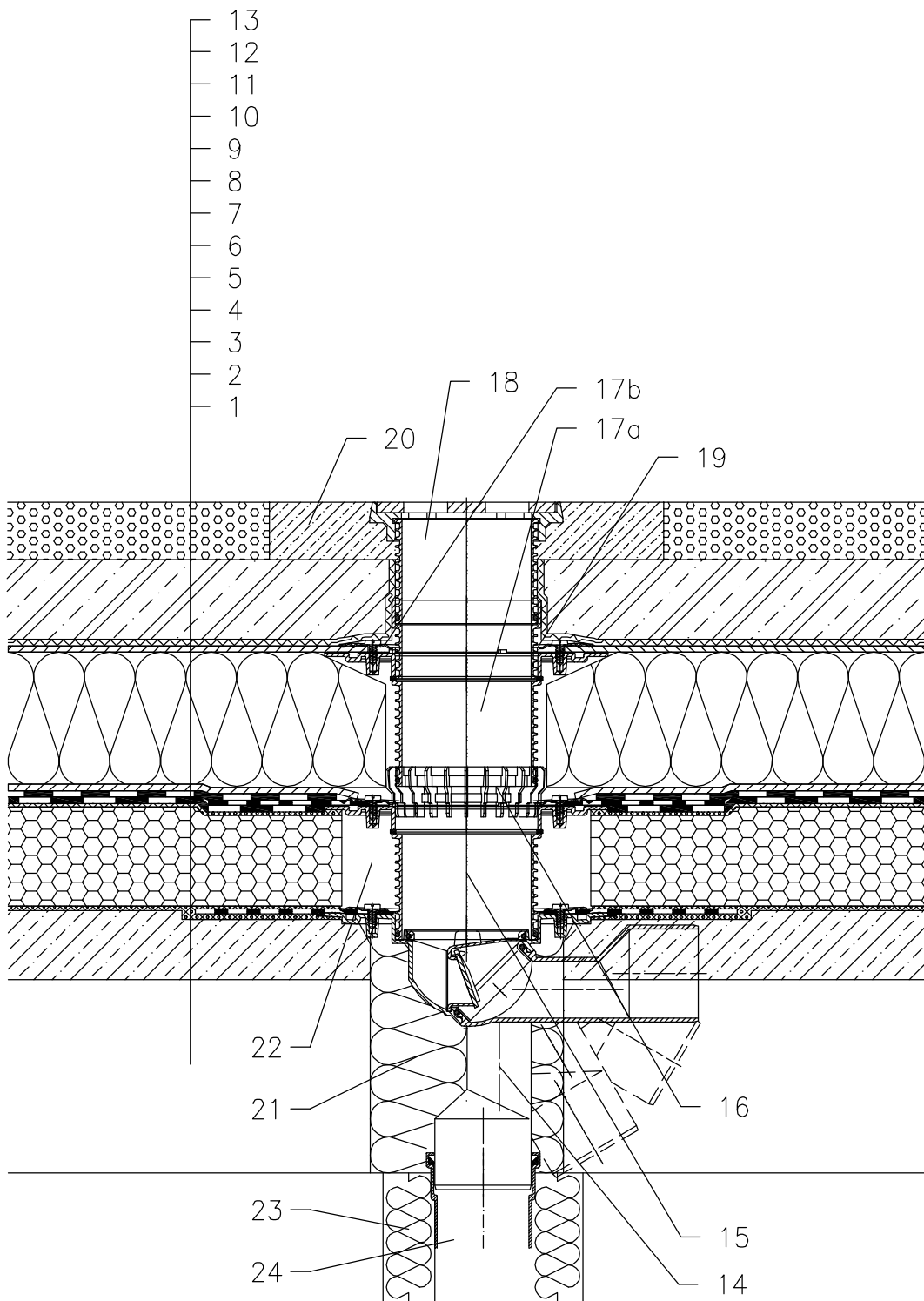

- 1 SUPPORT CONSTRUCTION
- 2 CONCRETE GRAVITY LAYER
- 3 HOT BITUMEN
- 4 THERMAL INSULATION – FOAMED GLASS
- 5 HOT BITUMEN
- 6 BITUMEN SHEET WATERPROOFING
- 7 BITUMEN SHEET WATERPROOFING
- 8 DRAINAGE LAYER
- 9 XPS THERMAL INSULATION
- 10 DRAINAGE LAYER
- 11 FILTER LAYER
- 12 REINFORCED CONCRETE
- 13 CAST ASPHALT
- 14 TERRACE DRAIN HL81GH WITH FROST-PROOF FLAP AND BITUMEN MEMBRANE WITH BITUMEN MEMBRANE  $\varnothing$ 400 mm, LOAD CLASSIFICATION L15 (MAX 1500 kg)
- 15 EXTENSION HL85NH WITH BITUMEN MEMBRANE  $\varnothing$ 400 mm; INCL. O-RING, (HL340N)
- 16 DRAINAGE RING HL180
- 17a EXTENSION HL85N WITH FLANGE INCL. O-RING, (HL340N)
- 17b SEALING KIT HL83.0
- 18 EXTENSION WITH CAST IRON GRATE 137x137 mm AND CAST IRON FRAME 150x150 mm (INCLUDED IN HL81GH)
- 19 NO TIGHT CONNECTION BECAUSE OF DISCHARGE OF LEAKAGE WATER
- 20 CONCRETE 1000x1000x100 mm
- 21 ASSEMBLY FOAM
- 22 FILL FREE SPACE WITH MINERAL WOOL
- 23 DOWNPIPE THERMAL INSULATION
- 24 DOWNPIPE

NOTICE:

TO HEAT THE DRAIN, YOU MAY USE HEATING KIT HL82 WITH SELF-REGULATING HEAT SOURCE 18W/220V. (THE HEATING TAPE MUST BE WRAPPED AROUND THE DRAIN BODY BEFORE INSTALLATION).

RECOMMENDED BOREHOLE DIAMETER IS  $\varnothing$ 150mm.

DURING INSTALLATION TAKE CARE, THAT THE FLANGE POSITION IS ON THE LOWEST LEVEL OF DRAINAGE. WE RECOMMEND, TO SITE IT APPR. 1cm BELOW THE SCREED.

TO AVOID CONDENSATE WATER TAKE CARE OF THERMAL INSULATION ON THE CONSTRUCTION SITE.

14221BX