

ROOF WITH THERMAL INSULATION – CAR PARK, COMBINED ORDER OF LAYERS
BITUMEN SHEETS

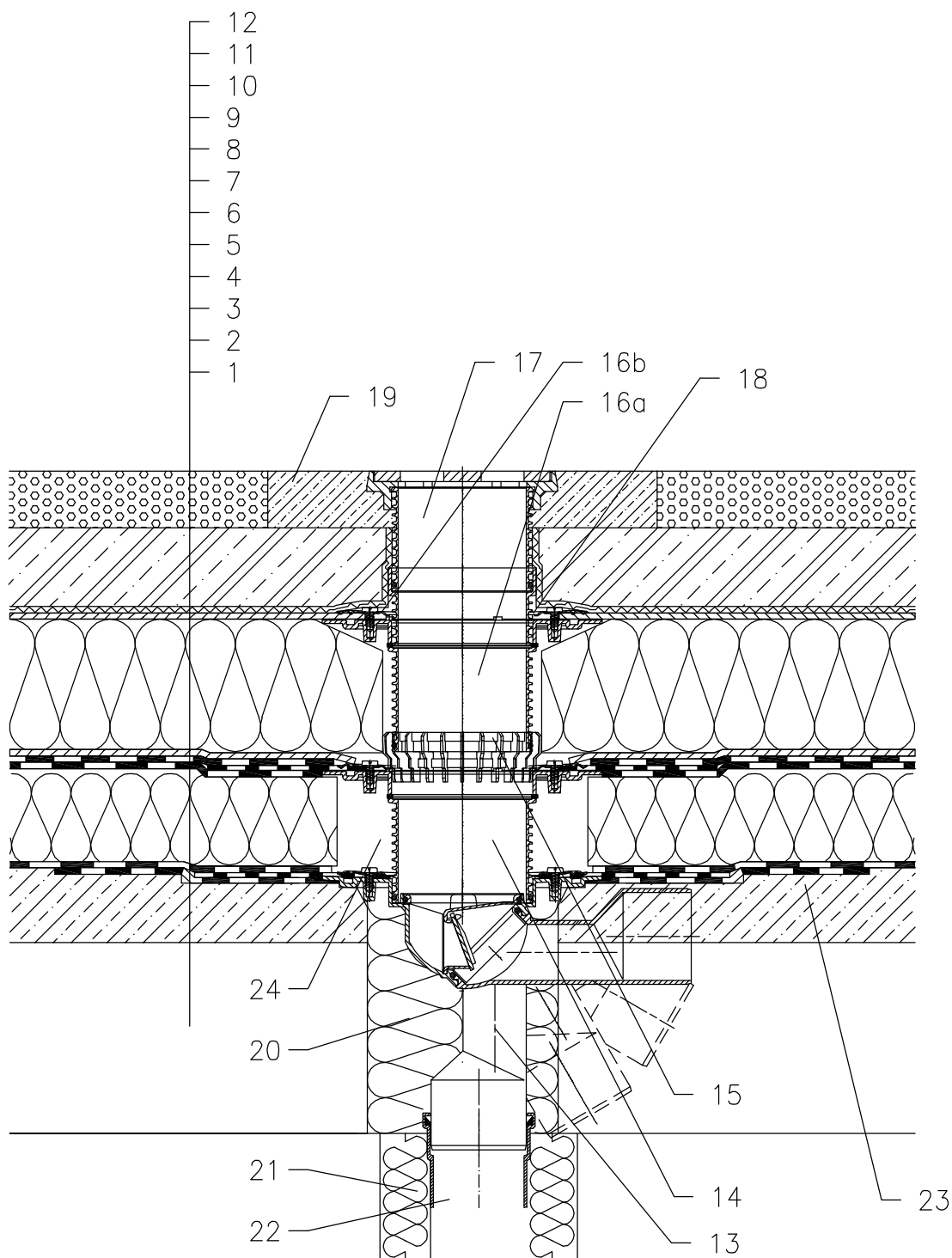

- 1 SUPPORT CONSTRUCTION
- 2 CONCRETE GRAVITY LAYER
- 3 MOISTURE STOP AND TEMPORARY SAFETY WATERPROOFING FROM BITUMEN SHEET
- 4 THERMAL INSULATION
- 5 BITUMEN SHEET WATERPROOFING NON SOLID GLUED OR LAID LOOSE
- 6 BITUMEN SHEET WATERPROOFING
- 7 DRAINAGE LAYER
- 8 XPS THERMAL INSULATION
- 9 DRAINAGE LAYER
- 10 FILTER LAYER
- 11 REINFORCED CONCRETE
- 12 CAST ASPHALT
- 13 TERRACE DRAIN HL81GH WITH FROST-PROOF FLAP AND BITUMEN MEMBRANE WITH BITUMEN MEMBRANE $\phi 400$ mm, LOAD CLASSIFICATION L15 (MAX 1500 kg)
- 14 EXTENSION HL85NH WITH BITUMEN MEMBRANE $\phi 400$ mm; INCL. O-RING, (HL340N)
- 15 DRAINAGE RING HL180
- 16a EXTENSION HL85N WITH FLANGE INCL. O-RING, (HL340N)
- 16b SEALING KIT HL83.0
- 17 EXTENSION WITH CAST IRON GRATE 137x137 mm AND CAST IRON FRAME 150x150 mm (INCLUDED IN HL81GH)
- 18 NO TIGHT CONNECTION BECAUSE OF DISCHARGE OF LEAKAGE WATER
- 19 CONCRETE 1000x1000x100 mm
- 20 ASSEMBLY FOAM
- 21 DOWNPIPE THERMAL INSULATION
- 22 DOWNPIPE
- 23 BITUMEN MEMBRANE $\phi 750$ mm
- 24 FILL FREE SPACE WITH MINERAL WOOL

NOTICE:

TO HEAT THE DRAIN, YOU MAY USE HEATING KIT HL82 WITH SELF-REGULATING HEAT SOURCE 18W/220V. (THE HEATING TAPE MUST BE WRAPPED AROUND THE DRAIN BODY BEFORE INSTALLATION).
RECOMMENDED BOREHOLE DIAMETER IS $\phi 150$ mm.
DURING INSTALLATION TAKE CARE, THAT THE FLANGE POSITION IS ON THE LOWEST LEVEL OF DRAINAGE. WE RECOMMEND, TO SITE IT APPR. 1cm BELOW THE SCREED.
TO AVOID CONDENSATE WATER TAKE CARE OF THERMAL INSULATION ON THE CONSTRUCTION SITE.

14221AX