

WARM ROOF – CAR PARK, COMBINED STRUCTURE, BITUMEN SHEET WATERPROOFING

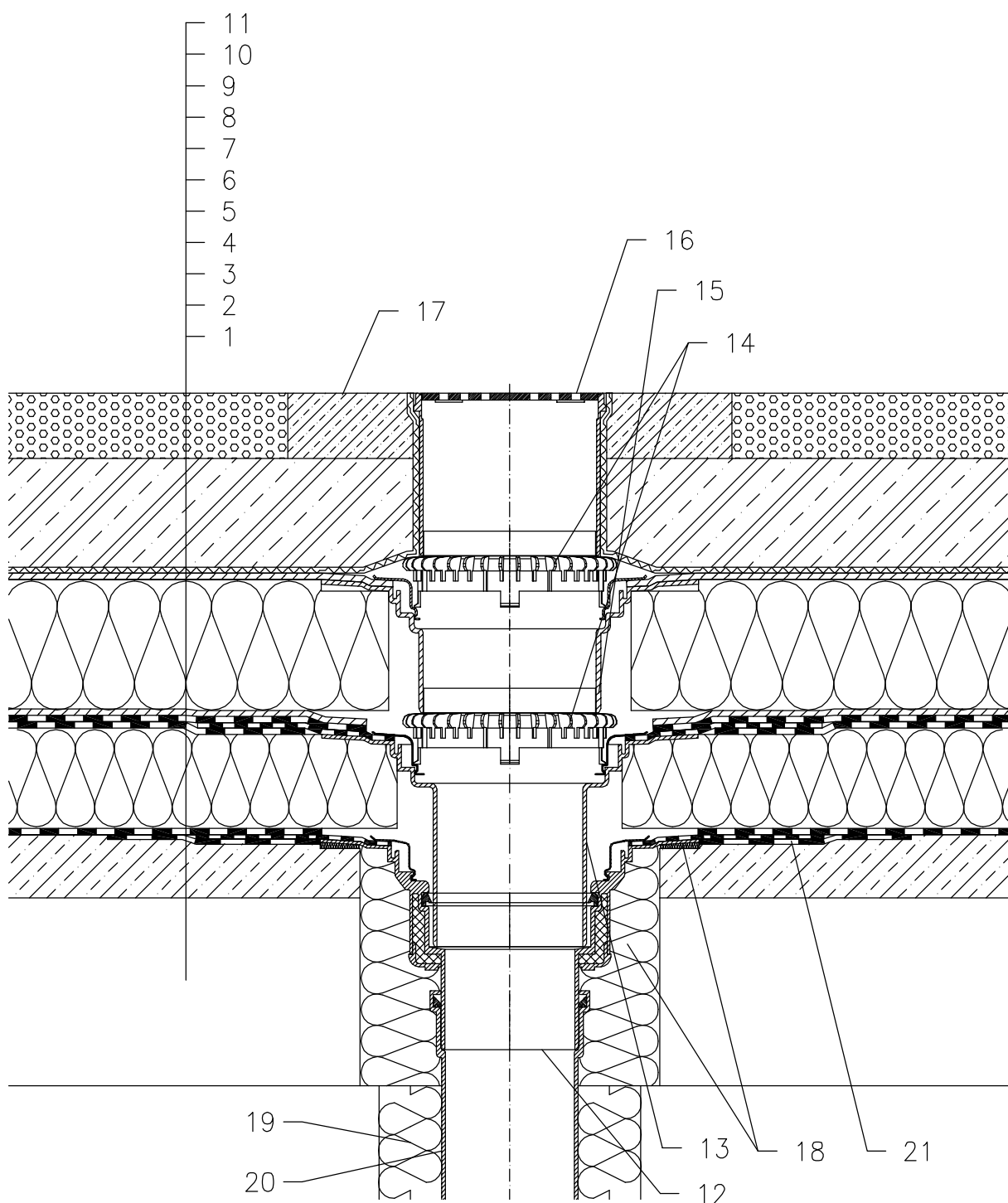

- 1 SUPPORT CONSTRUCTION
- 2 GRAVITY LAYER
- 3 MOISTURE STOP AND TEMPORARY SAFETY WATERPROOFING FROM BITUMEN SHEET
- 4 THERMAL INSULATION
- 5 BITUMEN SHEET WATERPROOFING NON-SOLID GLUED OR LAID LOOSE
- 6 DRAINAGE LAYER
- 7 THERMAL INSULATION FROM XPS
- 8 DRAINAGE LAYER
- 9 FILTER LAYER
- 10 REINFORCED CONCRETE SLAB
- 11 CAST ASPHALT
- 12 FLAT-ROOF DRAIN HL62H WITH INSULATED DRAIN BODY, WITH FACTORY WELDED BITUMEN MEMBRANE \varnothing 500 mm, THICKNESS 4 mm
- 13 EXTENSION HL65H WITH FLANGE AND FACTORY WELDED BITUMEN MEMBRANE \varnothing 500 mm, THICKNESS 4 mm
- 14 GRAVEL GUARD HL160
- 15 EXTENSION HL350.1 WITH FLANGE AND WATERPROOFING KIT HL84.0
- 16 GRATING HL66 (TRUNCATABLE) WITH STAINLESS STEEL FRAME AND SECURED STAINLESS STEEL GRATE, MAX. LOAD 1,5 t
- 17 CONCRETE BELT 1000 X 1000 X 100 mm
- 18 ASSEMBLY FOAM
- 19 DOWNPIPE THERMAL INSULATION
- 20 DOWNPIPE
- 21 BITUMEN MEMBRANE, \varnothing 750 mm

NOTE:

FLAT-ROOF DRAIN HL62.1H HEATED (230V, 10-30 WATTS) CAN BE USED.

ASSEMBLY INLET: \varnothing 220 MM, ALTERNATIVELY 240X360 MM

14221A