

ROOF WITH THERMAL INSULATION – COMBINED ORDER OF LAYERS, PAVERS ON STANDS  
PLASTIC FOIL

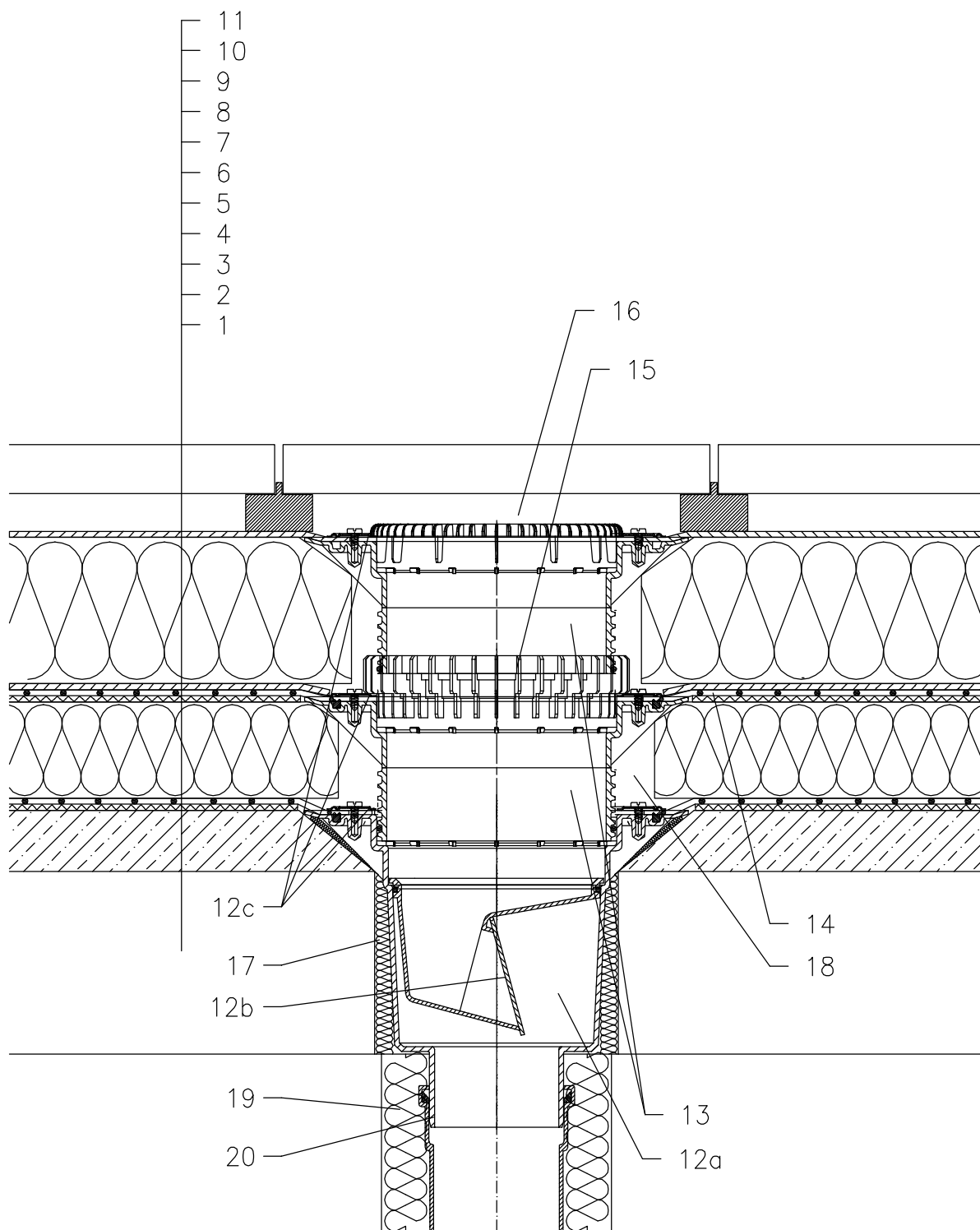

- 1 SUPPORT CONSTRUCTION
- 2 CONCRETE GRAVITY LAYER
- 3 SEPARATING AND DILATATION LAYER
- 4 MOISTURE STOP AND TEMPORARY SAFETY WATERPROOFING
- 5 THERMAL INSULATION
- 6 SEPARATING AND DILATATION LAYER
- 7 PLASTIC FOIL WATERPROOFING
- 8 DRAINAGE LAYER
- 9 XPS THERMAL INSULATION
- 10 SEPARATING LAYER
- 11 PAVERS ON STANDS
- 12a DRAIN BODY HL616K WITH FLANGE
- 12b FROST-PROOF FLAP HL0606.3E
- 12c SEALING KIT HL86.0 – WITHOUT SHEETING,
- 13 EXTENSION HL618 WITH FLANGE  
INCL. O-RING (HL620)
- 14 PRE-CUT PART FOR SEALING COLLAR, SEE TOPIC "ATTACHEMENTS"
- 15 DRAINAGE RING HL190
- 16 FLAT LEAF STRAINER HL191  
alternative LEAF STRAINER HL195
- 17 ASSEMBLY FOAM
- 18 FILL FREE SPACE WITH MINERAL WOOL
- 19 DOWNPIPE THERMAL INSULATION
- 20 DOWNPIPE

NOTICE:

TO HEAT THE DRAIN, YOU MAY USE HEATING KIT HL609 WITH SELF-REGULATING HEAT SOURCE 36W/230V. (THE HEATING TAPE MUST BE WRAPPED AROUND THE DRAIN BODY BEFORE INSTALLATION).  
RECOMMENDED BOREHOLE DIAMETER IS  $\phi 220\text{mm}$ , WITH HEATING KIT MIN.  $\phi 240\text{mm}$   
DURING INSTALLATION TAKE CARE, THAT THE FLANGE POSITION IS ON THE LOWEST LEVEL OF DRAINAGE. WE RECOMMEND, TO SITE IT APPR. 1cm BELOW THE SCREED.  
TO AVOID CONDENSATE WATER TAKE CARE OF THERMAL INSULATION ON THE CONSTRUCTION SITE.

142132Y