

ROOF WITH THERMAL INSULATION – COMBINED ORDER OF LAYERS, PAVERS ON STANDS
BITUMEN SHEETS

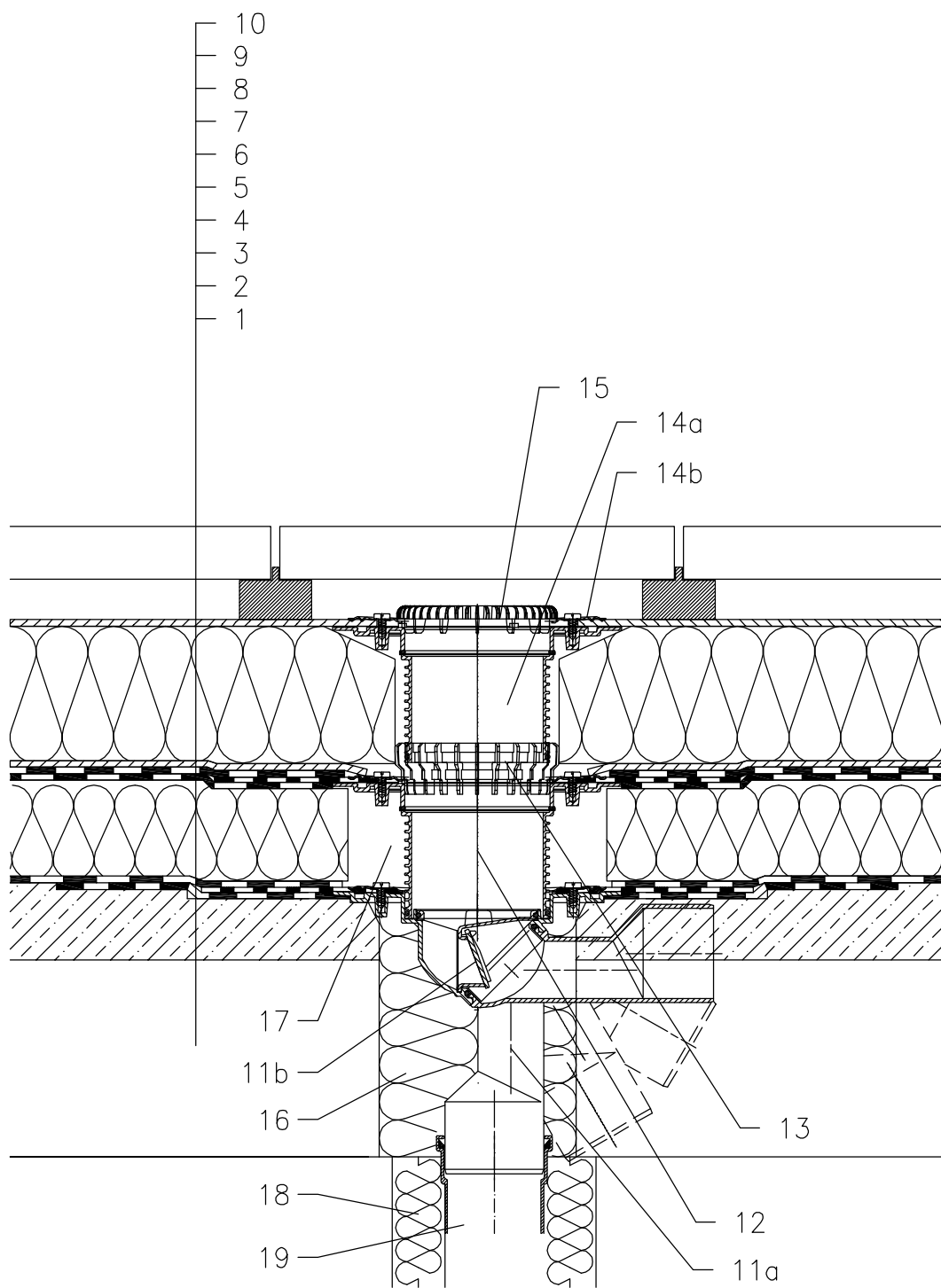

- 1 SUPPORT CONSTRUCTION
- 2 CONCRETE GRAVITY LAYER
- 3 MOISTURE STOP AND TEMPORARY SAFETY WATERPROOFING FROM BITUMEN SHEET
- 4 THERMAL INSULATION
- 5 BITUMEN SHEET WATERPROOFING NON SOLID GLUED OR LAID LOOSE
- 6 BITUMEN SHEET WATERPROOFING
- 7 DRAINAGE LAYER
- 8 XPS THERMAL INSULATION
- 9 SEPARATION LAYER
- 10 PAVERS ON STANDS
- 11a DRAIN BODY HL80HK WITH BITUMEN MEMBRANE ϕ 400 mm,
- 11b FROST-PROOF FLAP HL080.4E
- 12 EXTENSION HL85NH WITH BITUMEN MEMBRANE ϕ 400 mm; INCL. O-RING, (HL340N)
- 13 DRAINAGE RING HL180
- 14a EXTENSION HL85N WITH FLANGE INCL. O-RING, (HL340N)
- 14b SEALING KIT HL83.0
- 15 FLAT LEAF STRAINER HL181 alternative LEAF STRAINER HL080.8E
- 16 ASSEMBLY FOAM
- 17 FILL FREE SPACE WITH MINERAL WOOL
- 18 DOWNPIPE THERMAL INSULATION
- 19 DOWNPIPE
- 20 BITUMEN MEMBRANE ϕ 750 mm

NOTICE:

TO HEAT THE DRAIN, YOU MAY USE HEATING KIT HL82 WITH SELF-REGULATING HEAT SOURCE 18W/220V. (THE HEATING TAPE MUST BE WRAPPED AROUND THE DRAIN BODY BEFORE INSTALLATION).

RECOMMENDED BOREHOLE DIAMETER IS ϕ 150mm.

DURING INSTALLATION TAKE CARE, THAT THE FLANGE POSITION IS ON THE LOWEST LEVEL OF DRAINAGE. WE RECOMMEND, TO SITE IT APPR. 1cm BELOW THE SCREED.

TO AVOID CONDENSATE WATER TAKE CARE OF THERMAL INSULATION ON THE CONSTRUCTION SITE.

142131AX