

WARM ROOF – LOADED SYSTEM, COMBINED COMPACT STRUCTURE  
 TRAPEZOIDAL PLATE SUPPORTING STRUCTURE, BITUMEN SHEET WATERPROOFING

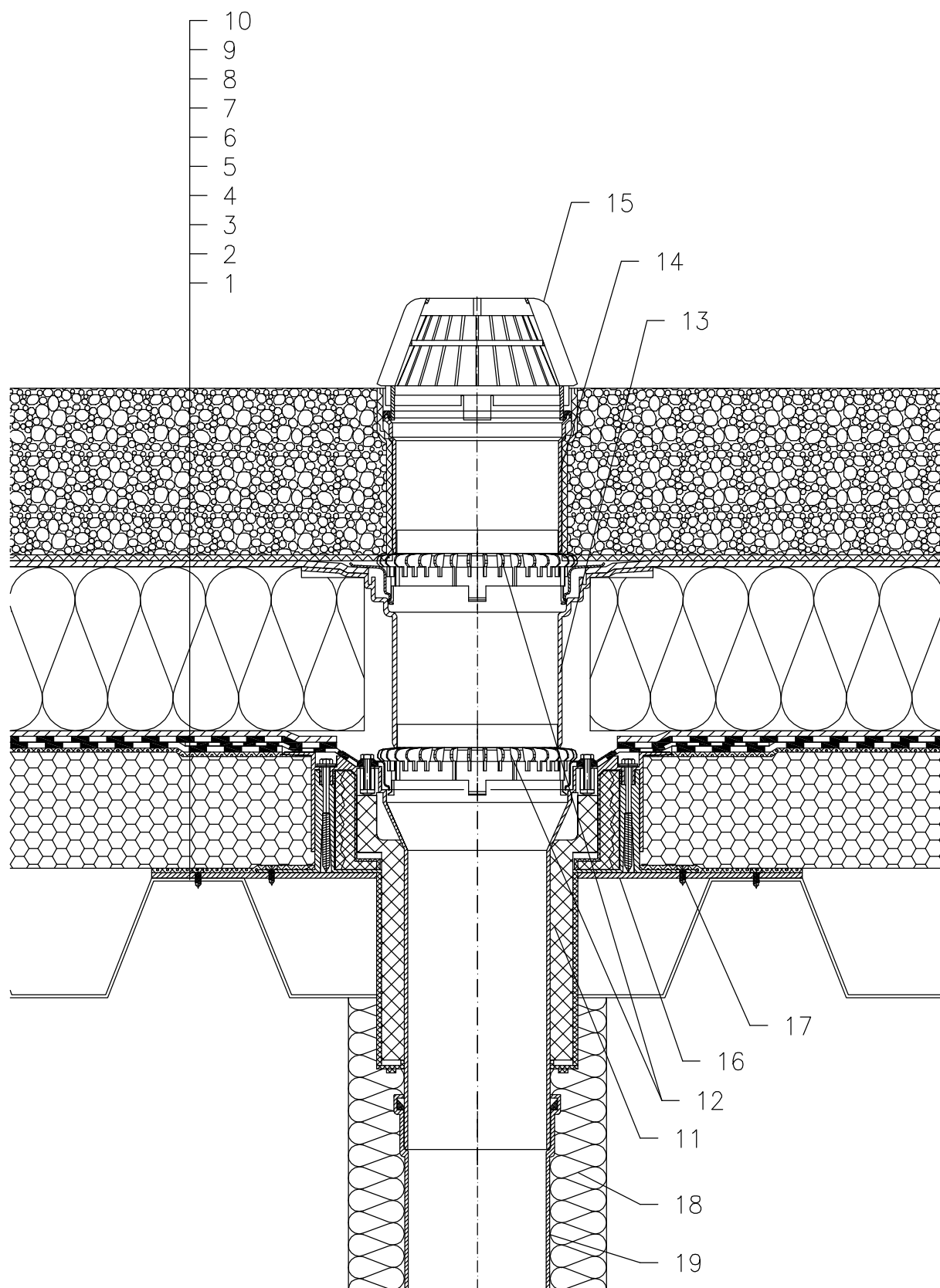

- 1 TRAPEZOIDAL PLATE
- 2 HOT BITUMEN
- 3 THERMAL INSULATION – CELLULAR GLASS
- 4 HOT BITUMEN
- 5 BITUMEN SHEET WATERPROOFING SOLID GLUED
- 6 DRAINAGE LAYER
- 7 THERMAL INSULATION FROM XPS
- 8 DRAINAGE LAYER
- 9 FILTER LAYER
- 10 STABILIZING LAYER
- 11 FLAT-ROOF DRAIN HL63H DRAINBOX, WITH INSULATED DRAIN BODY, TELESCOPED OUTER-HOUSING FOR PRECISE ADJUSTMENTS TO INSULATIONS 100–160 mm, FACTORY WELDED BITUMEN MEMBRANE  $\varnothing$ 500 mm, THICKNESS 4 mm
- 12 GRAVEL GUARD HL160
- 13 EXTENSION HL350.1 WITH FLANGE AND WATERPROOFING KIT HL84.0
- 14 EXTENSION HL350
- 15 DOMED PLASTIC GRATE  $\varnothing$ 180 mm (INCL. WITH HL63H)
- 16 MOUNTING METAL PLATE
- 17 ANCHOR BOLT
- 18 DOWNPIPE THERMAL INSULATION
- 19 DOWNPIPE

NOTE:  
 FLAT-ROOF DRAIN HL63.1H HEATED (230V, 10–30 WATTS) CAN BE USED.  
 ASSEMBLY INLET:  $\varnothing$ 200 MM