

ROOF WITH THERMAL INSULATION – CAR PARK, REVERSE ORDER OF LAYERS, PLASTIC FOIL

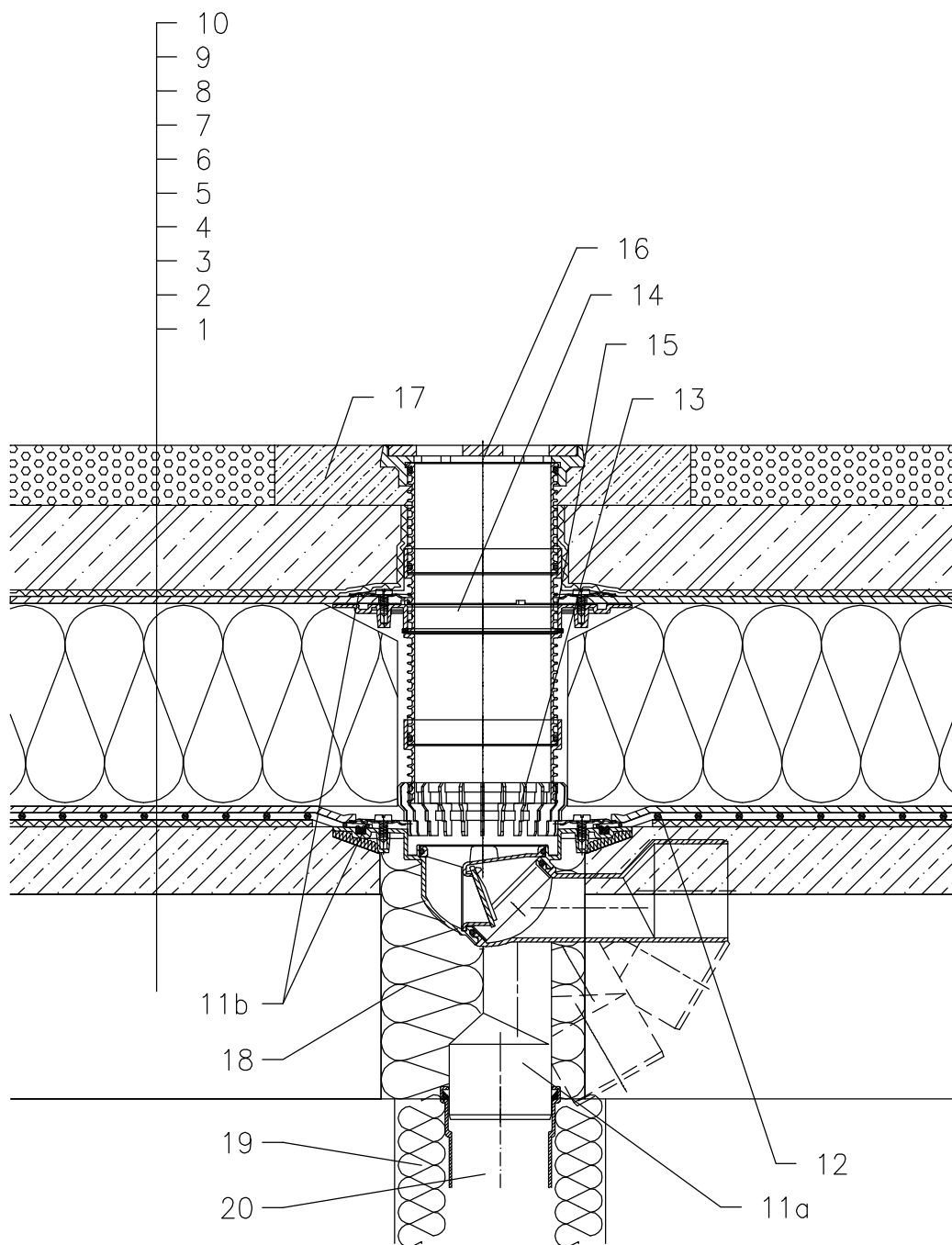

- 1 SUPPORT CONSTRUCTION
- 2 CONCRETE GRAVITY LAYER
- 3 SEPARATING AND DILATATION LAYER
- 4 PLASTIC FOIL WATERPROOFING
- 5 SEPARATING AND DRAINAGE LAYER
- 6 XPS THERMAL INSULATION
- 7 DRAINAGE LAYER
- 8 FILTER LAYER
- 9 REINFORCED CONCRETE
- 10 CAST ASPHALT
- 11a TERRACE DRAIN HL81G WITH FROST-PROOF FLAP AND FLANGE
LOAD CLASSIFICATION L15 (MAX 1500 kg)
- 11b SEALING KIT HL83.0 – WITHOUT SHEETING,
(ALL-PURPOSE FOR UNRUFFED ROOF SHEETINGS)
(alternative HL83.P – WHEN USING PVC SHEETINGS)
- 12 PRE-CUT PART FOR SEALING COLLAR, SEE TOPIC "ATTACHEMENTS"
- 13 DRAINAGE RING HL180
- 14 EXTENSION HL85N WITH FLANGE
INCL. O-RING
- 15 NO TIGHT CONNECTION BECAUSE OF DISCHARGE OF LEAKAGE WATER
- 16 EXTENSION WITH CAST IRON GRATE 137x137 mm
AND CAST IRON FRAME 150x150 mm
(INCLUDED IN HL81G)
- 17 CONCRETE 1000x1000x100 mm
- 18 ASSEMBLY FOAM
- 19 DOWNPIPE THERMAL INSULATION
- 20 DOWNPIPE

NOTICE:

TO HEAT THE DRAIN, YOU MAY USE HEATING KIT HL82 WITH SELF-REGULATING HEAT SOURCE 18W/220V. (THE HEATING TAPE MUST BE WRAPPED AROUND THE DRAIN BODY BEFORE INSTALLATION).

RECOMMENDED BOREHOLE DIAMETER IS $\varnothing 150\text{mm}$.

DURING INSTALLATION TAKE CARE, THAT THE FLANGE POSITION IS ON THE LOWEST LEVEL OF DRAINAGE. WE RECOMMEND, TO SITE IT APPR. 1cm BELOW THE SCREED.

TO AVOID CONDENSATE WATER TAKE CARE OF THERMAL INSULATION ON THE CONSTRUCTION SITE.

13222AX