

# ROOF WITH THERMAL INSULATION – CAR PARK, REVERSE ORDER OF LAYERS, BITUMEN SHEETS

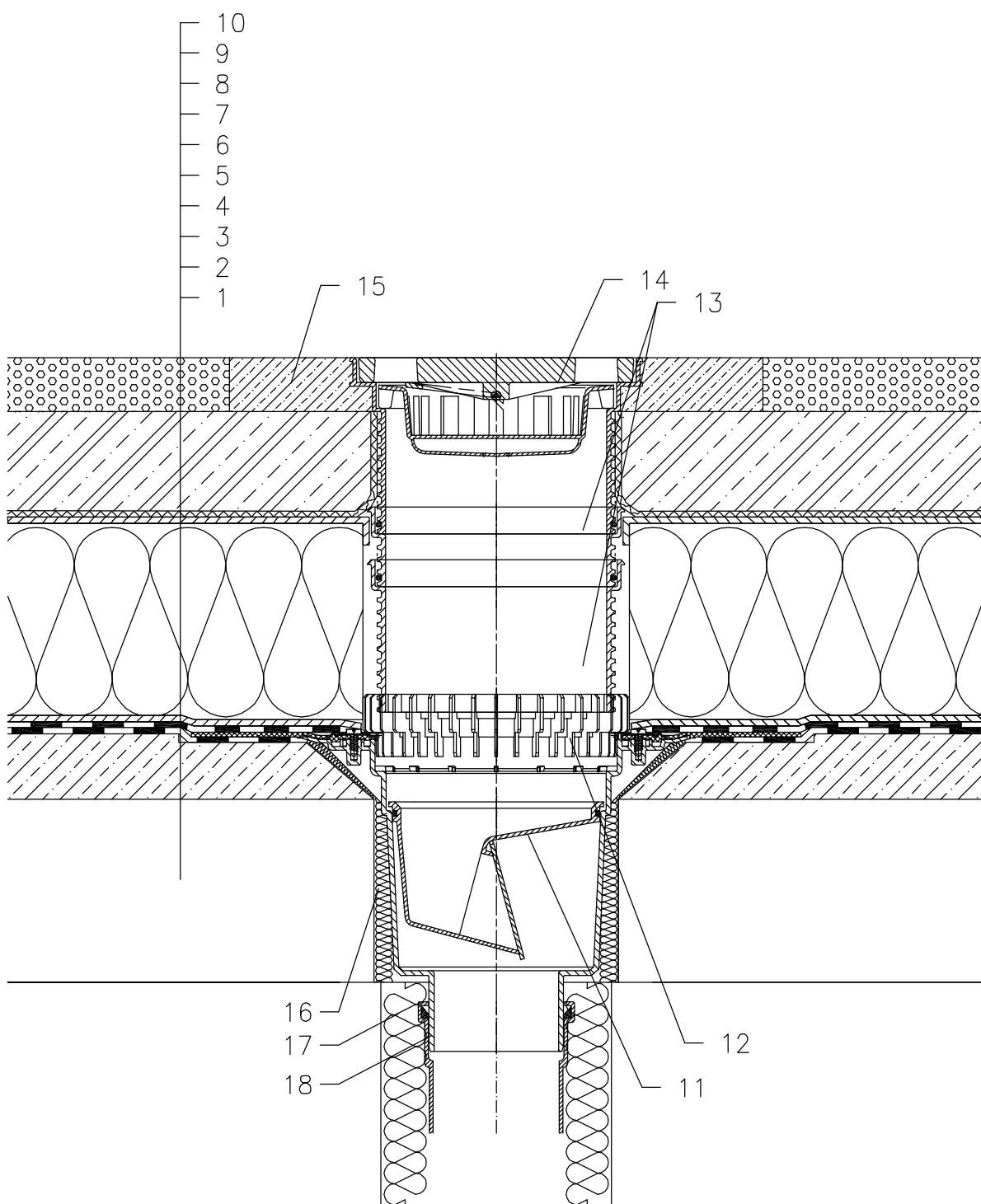

- 1 SUPPORT CONSTRUCTION
- 2 CONCRETE GRAVITY LAYER
- 3 BITUMEN SHEET WATERPROOFING  
NON SOLID GLUED OR LAID LOOSE
- 4 BITUMEN SHEET WATERPROOFING
- 5 DRAINAGE LAYER
- 6 XPS THERMAL INSULATION
- 7 DRAINAGE LAYER
- 8 FILTER LAYER
- 9 REINFORCED CONCRETE
- 10 CAST ASPHALT
- 11 TERRACE DRAIN HL616H WITH FROST-PROOF FLAP  
AND BITUMEN MEMBRANE  
LOAD CLASSIFICATION L15 (MAX 1500 kg)  
alternative DRAIN HL616.1H, LOAD CLASSIFICATION M125 (MAX 12,5 t)
- 12 DRAINAGE RING HL190
- 13 EXTENSION HL620
- 14 EXTENSION WITH CAST IRON GRATE 226x226 mm  
AND PLASTIC FRAME 240x240 mm  
(INCLUDED IN HL616H)
- 15 CONCRETE 1000x1000x100 mm
- 16 ASSEMBLY FOAM
- 17 DOWNPIPE THERMAL INSULATION
- 18 DOWNPIPE

## NOTICE:

TO HEAT THE DRAIN, YOU MAY USE HEATING KIT HL609 WITH SELF-REGULATING HEAT SOURCE 36W/230V. (THE HEATING TAPE MUST BE WRAPPED AROUND THE DRAIN BODY BEFORE INSTALLATION).  
RECOMMENDED BOREHOLE DIAMETER IS  $\varnothing 220\text{mm}$ , WITH HEATING KIT MIN.  $\varnothing 240\text{mm}$   
DURING INSTALLATION TAKE CARE, THAT THE FLANGE POSITION IS ON THE LOWEST LEVEL OF DRAINAGE. WE RECOMMEND, TO SITE IT APPR. 1cm BELOW THE SCREED.  
TO AVOID CONDENSATE WATER TAKE CARE OF THERMAL INSULATION ON THE CONSTRUCTION SITE.

13221BY