

WARM ROOF – CAR PARK, REVERSE LAYER ORDER STRUCTURE, BITUMEN SHEET WATERPROOFING

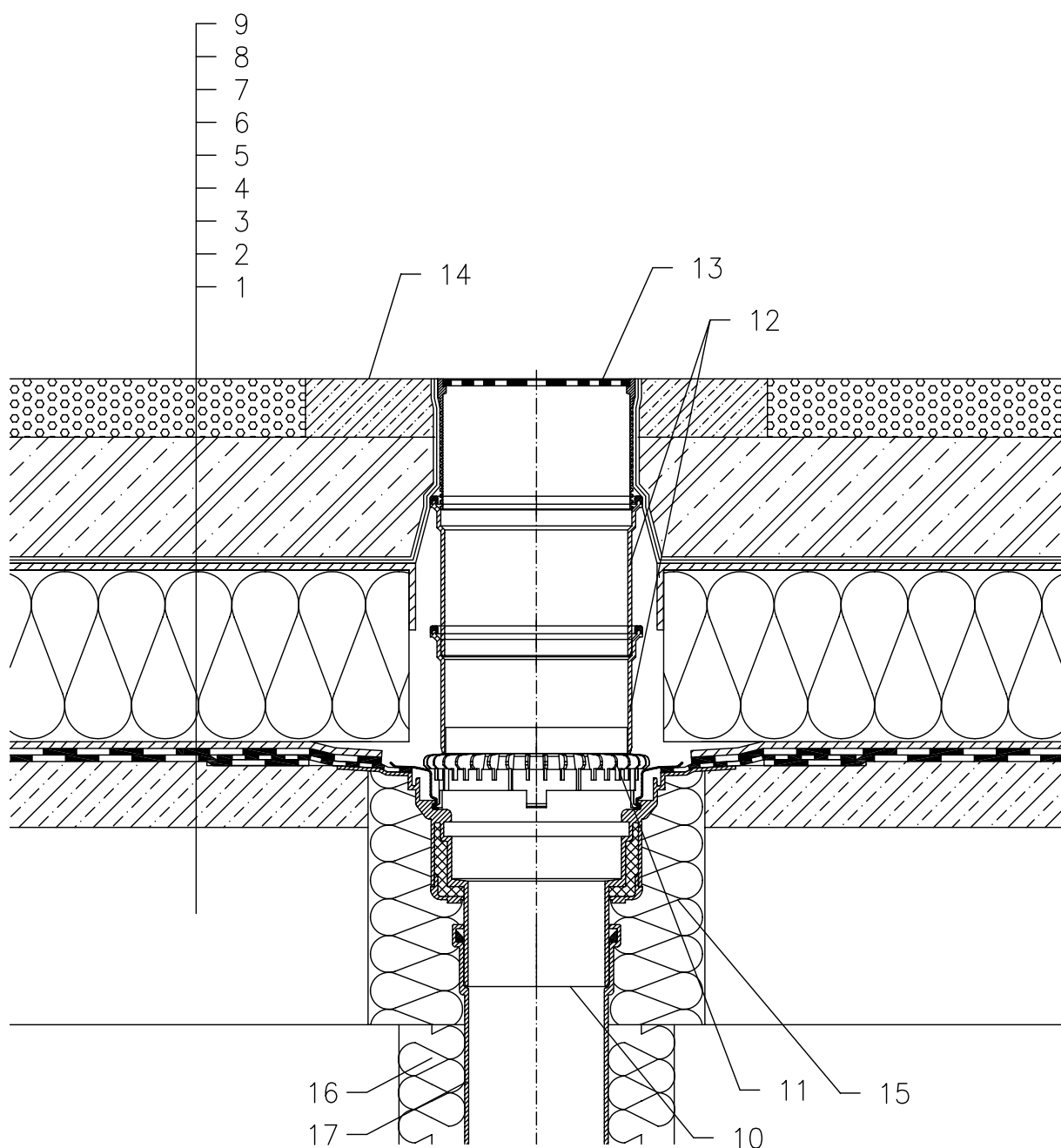

- 1 SUPPORT CONSTRUCTION
- 2 GRAVITY LAYER
- 3 BITUMEN SHEET WATERPROOFING NON-SOLID GLUED OR LAID LOOSE
- 4 DRAINAGE LAYER
- 5 THERMAL INSULATION FROM XPS
- 6 DRAINAGE LAYER
- 7 FILTER LAYER
- 8 REINFORCED CONCRETE SLAB
- 9 CAST ASPHALT
- 10 FLAT-ROOF DRAIN HL62H WITH INSULATED DRAIN BODY, WITH FACTORY WELDED BITUMEN MEMBRANE \varnothing 500 mm, THICKNESS 4 mm
- 11 GRAVEL GUARD HL160
- 12 EXTENSION HL350
- 13 GRATING HL66 (TRUNCATABLE) WITH STAINLESS STEEL FRAME AND SECURED STAINLESS STEEL GRATE, MAX. LOAD 1,5 t
- 14 CONCRETE BELT 1000 X 1000 X 100 mm
- 15 ASSEMBLY FOAM
- 16 DOWNPIPE THERMAL INSULATION
- 17 DOWNPIPE

NOTE:

FLAT-ROOF DRAIN HL62.1H HEATED (230V, 10-30 WATTS) CAN BE USED.

ASSEMBLY INLET: \varnothing 220 MM, ALTERNATIVELY 240X360 MM

13221B