

ROOF WITH THERMAL INSULATION – PAVERS ON STANDS, REVERSE ORDER OF LAYERS
PLASTIC FOIL

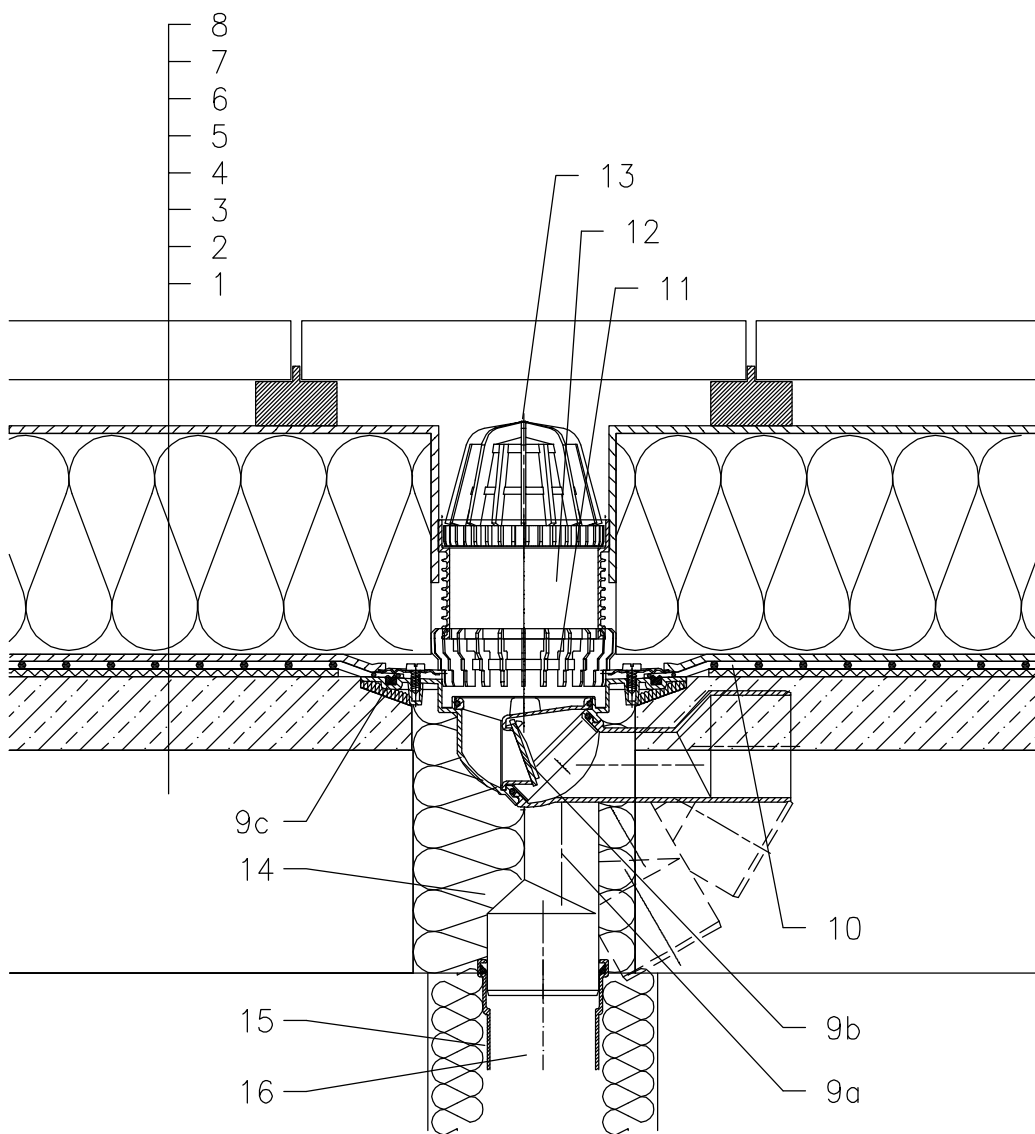

- 1 SUPPORT CONSTRUCTION
- 2 CONCRETE GRAVITY LAYER
- 3 SEPARATING LAYER
- 4 PLASTIC FOIL WATERPROOFING
- 5 SEPARATING AND DRAINAGE LAYER
- 6 XPS THERMAL INSULATION
- 7 SEPARATION LAYER
- 8 PAVERS ON STANDS
- 9a DRAIN BODY HL80.3 WITH FLANGE
- 9b SEALING KIT HL83.0 – WITHOUT SHEETING,
(ALL-PURPOSE FOR UNRUFFED ROOF SHEETINGS)
(alternative HL83.P – WHEN USING PVC SHEETINGS)
- 9c FROST-PROOF FLAP HL080.4E
(NOT INCLUDED IN HL80.3)
- 10 PRE-CUT PART FOR SEALING COLLAR, SEE TOPIC "ATTACHEMENTS"
- 11 DRAINAGE RING HL180
- 12 EXTENSION HL340N
- 13 LEAF STRAINER (INCLUDED IN HL80.3), alt. HL181
- 14 ASSEMBLY FOAM
- 15 DOWNPIPE THERMAL INSULATION
- 16 DOWNPIPE

NOTICE:

TO HEAT THE DRAIN, YOU MAY USE HEATING KIT HL82 WITH SELF-REGULATING HEAT SOURCE 18W/220V. (THE HEATING TAPE MUST BE WRAPPED AROUND THE DRAIN BODY BEFORE INSTALLATION).

RECOMMENDED BOREHOLE DIAMETER IS $\phi 150\text{mm}$.

DURING INSTALLATION TAKE CARE, THAT THE FLANGE POSITION IS ON THE LOWEST LEVEL OF DRAINAGE. WE RECOMMEND, TO SITE IT APPR. 1cm BELOW THE SCREED.

TO AVOID CONDENSATE WATER TAKE CARE OF THERMAL INSULATION ON THE CONSTRUCTION SITE.

132132BX