

WARM ROOF – WALKABLE, REVERSE LAYER ORDER STRUCTURE, PLASTIC FOIL WATERPROOFING
PAVEMENT IN SAND SUBBASE

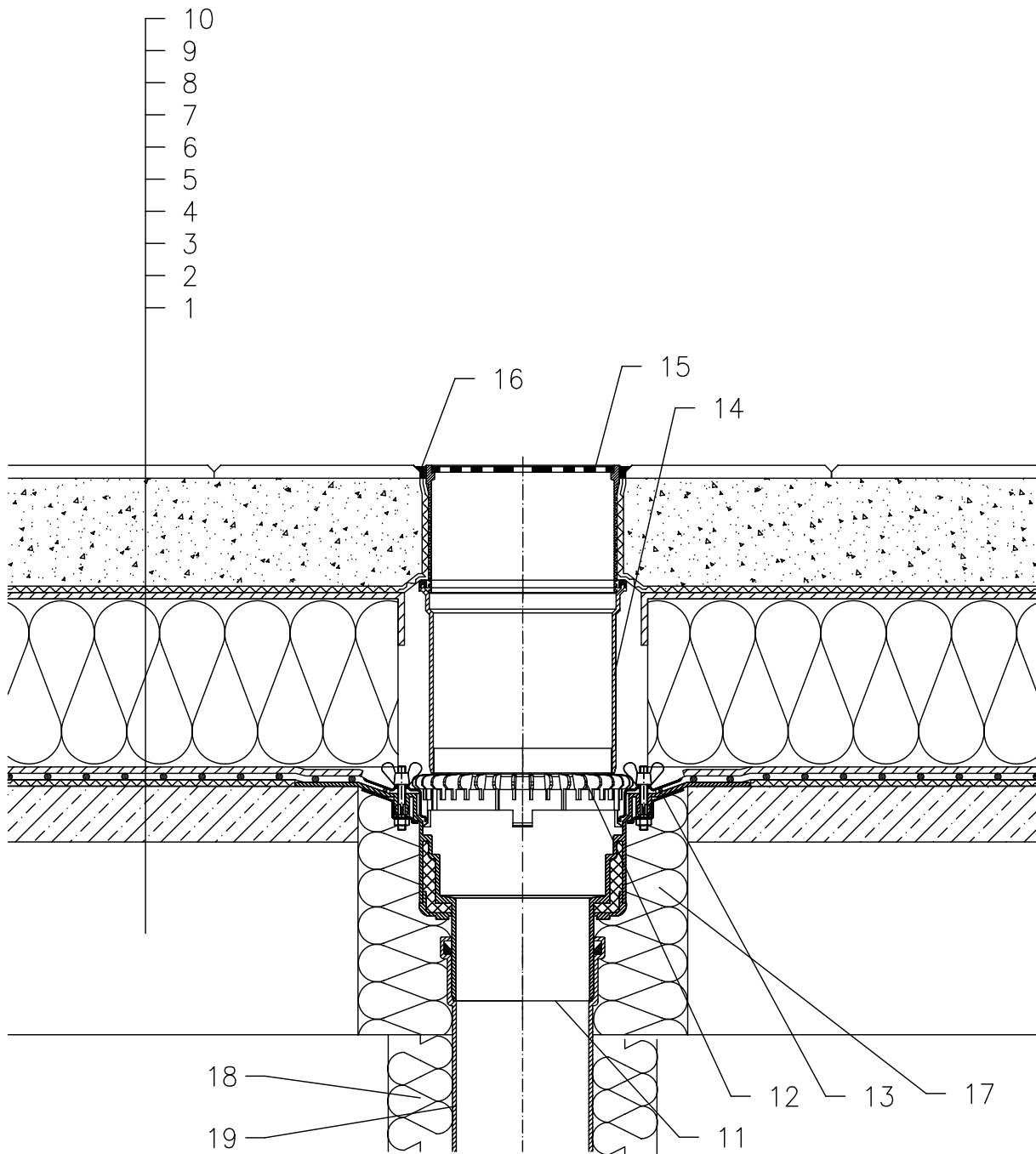

- 1 SUPPORT CONSTRUCTION
- 2 GRAVITY LAYER
- 3 DILATATION LAYER
- 4 PLASTIC FOIL WATERPROOFING LAID LOOSE
- 5 DILATATION AND DRAINAGE LAYER
- 6 THERMAL INSULATION FROM XPS
- 7 DRAINAGE LAYER
- 8 FILTER LAYER
- 9 SAND SUBBASE
- 10 PAVEMENT
- 11 FLAT-ROOF DRAIN HL62B WITH INSULATED DRAIN BODY, FLANGE AND STAINLESS STEEL CLAMPING RING
- 12 GRAVEL GUARD HL160
- 13 SEALING PACKING (SEE DETAIL-ACCESSORIES)
- 14 EXTENSION HL350
- 15 GRATING HL66.9 WITH STAINLESS STEEL GRATE 150x150 mm CHARGEABLE TO 300 kg (INCL. WITH HL62B)
- 16 NON-HARDENING MASTIC
- 17 ASSEMBLY FOAM
- 18 DOWNPIPE THERMAL INSULATION
- 19 DOWNPIPE

NOTE:

FLAT-ROOF DRAIN HL62.1B HEATED (230V, 10-30 WATTS) CAN BE USED.

ASSEMBLY INLET: \varnothing 220 MM, ALTERNATIVELY 240X360 MM

132122B