

ROOF WITH THERMAL INSULATION – PAVEMENT IN SUBBASE, REVERSE ORDER OF LAYERS
PLASTIC FOIL

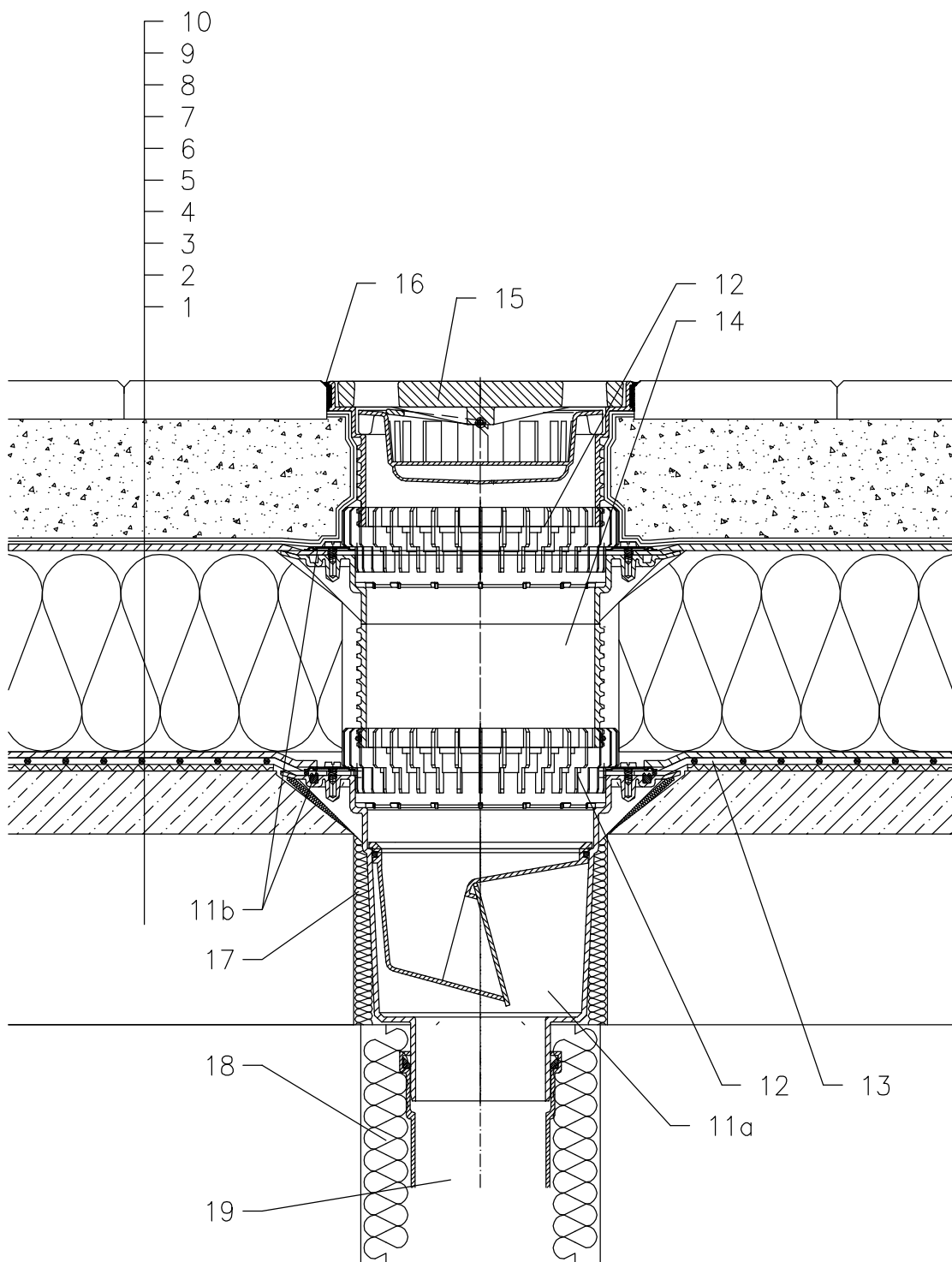

- 1 SUPPORT CONSTRUCTION
- 2 CONCRETE GRAVITY LAYER
- 3 SEPARATING AND DILATATION LAYER
- 4 PLASTIC FOIL WATERPROOFING
- 5 SEPARATING AND DRAINAGE LAYER
- 6 XPS THERMAL INSULATION
- 7 DRAINAGE LAYER
- 8 FILTER LAYER
- 9 SAND SUBBASE
- 10 PAVEMENT
- 11a TERRACE DRAIN HL616 WITH FROST-PROOF FLAP AND FLANGE
LOAD CLASSIFICATION L15 (MAX 1500 kg)
- 11b SEALING KIT HL86.0 – WITHOUT SHEETING,
- 12 DRAINAGE RING HL190
- 13 PRE-CUT PART FOR SEALING COLLAR, SEE TOPIC "ATTACHEMENTS"
- 14 EXTENSION HL618 WITH FLANGE
INCL. O-RING
- 15 EXTENSION WITH CAST IRON GRATE 226x226 mm
AND PLASTIC FRAME 240x240 mm
(INCLUDED IN HL616)
alternative HL616S – WITH STAINLESS STEEL GRATE
alternative HL616L – WITH PLASTIC GRATE
- 16 NON-HARDENING MASTIC
- 17 ASSEMBLY FOAM
- 18 DOWNPIPE THERMAL INSULATION
- 19 DOWNPIPE

NOTICE:

TO HEAT THE DRAIN, YOU MAY USE HEATING KIT HL609 WITH SELF-REGULATING HEAT SOURCE 36W/230V. (THE HEATING TAPE MUST BE WRAPPED AROUND THE DRAIN BODY BEFORE INSTALLATION).
RECOMMENDED BOREHOLE DIAMETER IS $\varnothing 220\text{mm}$, WITH HEATING KIT MIN. $\varnothing 240\text{mm}$
DURING INSTALLATION TAKE CARE, THAT THE FLANGE POSITION IS ON THE LOWEST LEVEL OF DRAINAGE. WE RECOMMEND, TO SITE IT APPR. 1cm BELOW THE SCREED.
TO AVOID CONDENSATE WATER TAKE CARE OF THERMAL INSULATION ON THE CONSTRUCTION SITE.

132122AY