

WARM ROOF – WALKABLE, REVERSE LAYER ORDER STRUCTURE, PLASTIC FOIL WATERPROOFING
PAVEMENT GLUED

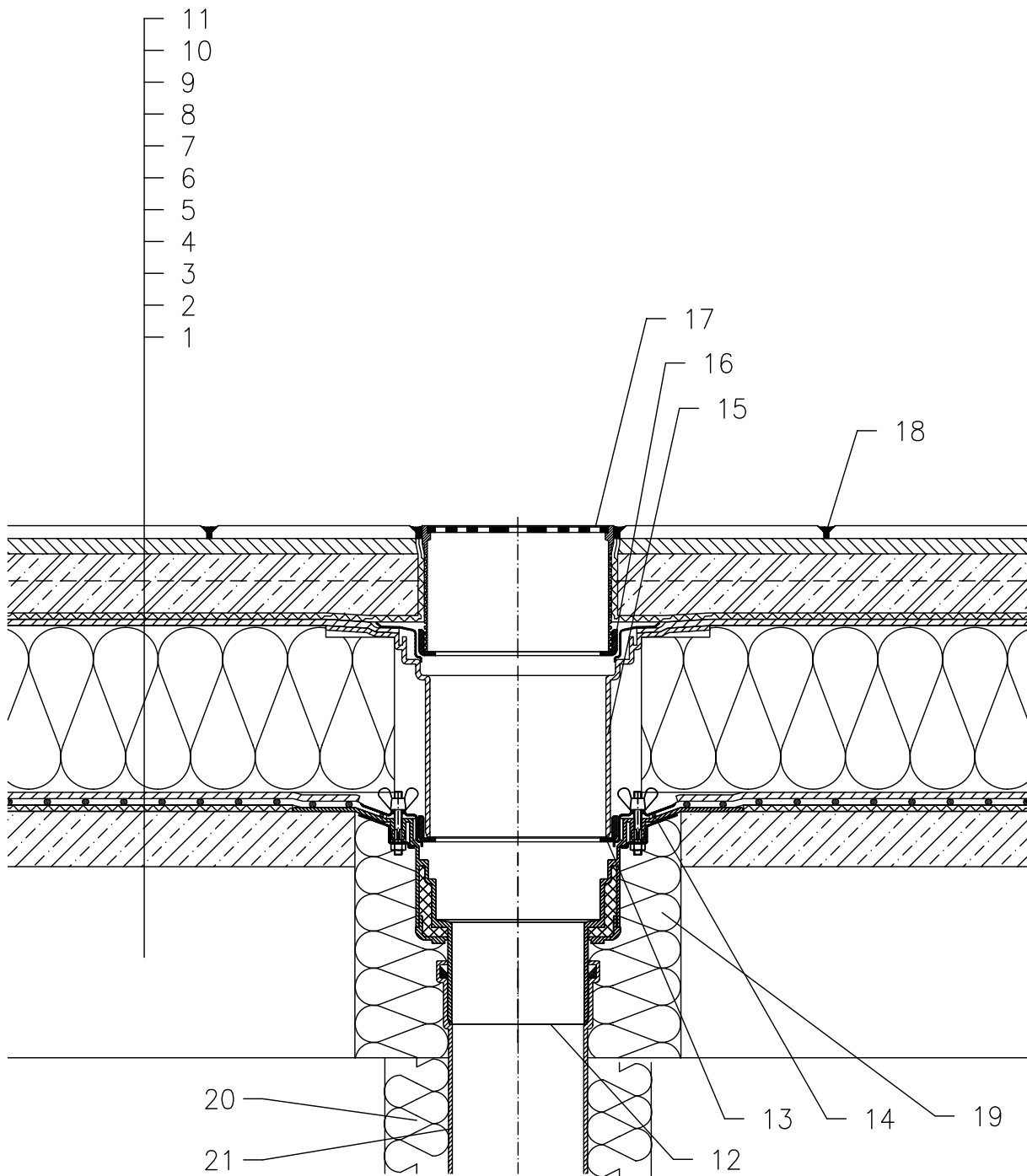

- 1 SUPPORT CONSTRUCTION
- 2 GRAVITY LAYER
- 3 DILATATION LAYER
- 4 PLASTIC FOIL WATERPROOFING LAID LOOSE
- 5 DILATATION AND DRAINAGE LAYER
- 6 THERMAL INSULATION FROM XPS
- 7 DRAINAGE LAYER
- 8 FILTER LAYER
- 9 CONCRETE SLAB
- 10 MORTAR BED OR GLUE
- 11 PAVEMENT
- 12 FLAT-ROOF DRAIN HL62B WITH INSULATED DRAIN BODY, FLANGE AND STAINLESS STEEL CLAMPING RING
- 13 ADAPTER 062B.3E (INCL. WITH HL62B)
- 14 SEALING PACKING (SEE DETAIL-ACCESSORIES)
- 15 EXTENSION HL350.1 WITH FLANGE AND WATERPROOFING KIT HL84.0
- 16 ADAPTER 062B.3E
- 17 GRATING HL66.9 WITH STAINLESS STEEL GRATE 150x150 mm CHARGEABLE TO 300 kg (INCL. WITH HL62B)
- 18 JOINT FILLER
- 19 ASSEMBLY FOAM
- 20 DOWNPIPE THERMAL INSULATION
- 21 DOWNPIPE

NOTE:

FLAT-ROOF DRAIN HL62.1B HEATED (230V, 10-30 WATTS) CAN BE USED.

ASSEMBLY INLET: \varnothing 220 MM, ALTERNATIVELY 240X360 MM

132112A