

WARM ROOF – WALKABLE, REVERSE LAYER ORDER STRUCTURE, BITUMEN SHEET WATERPROOFING  
PAVEMENT GLUED

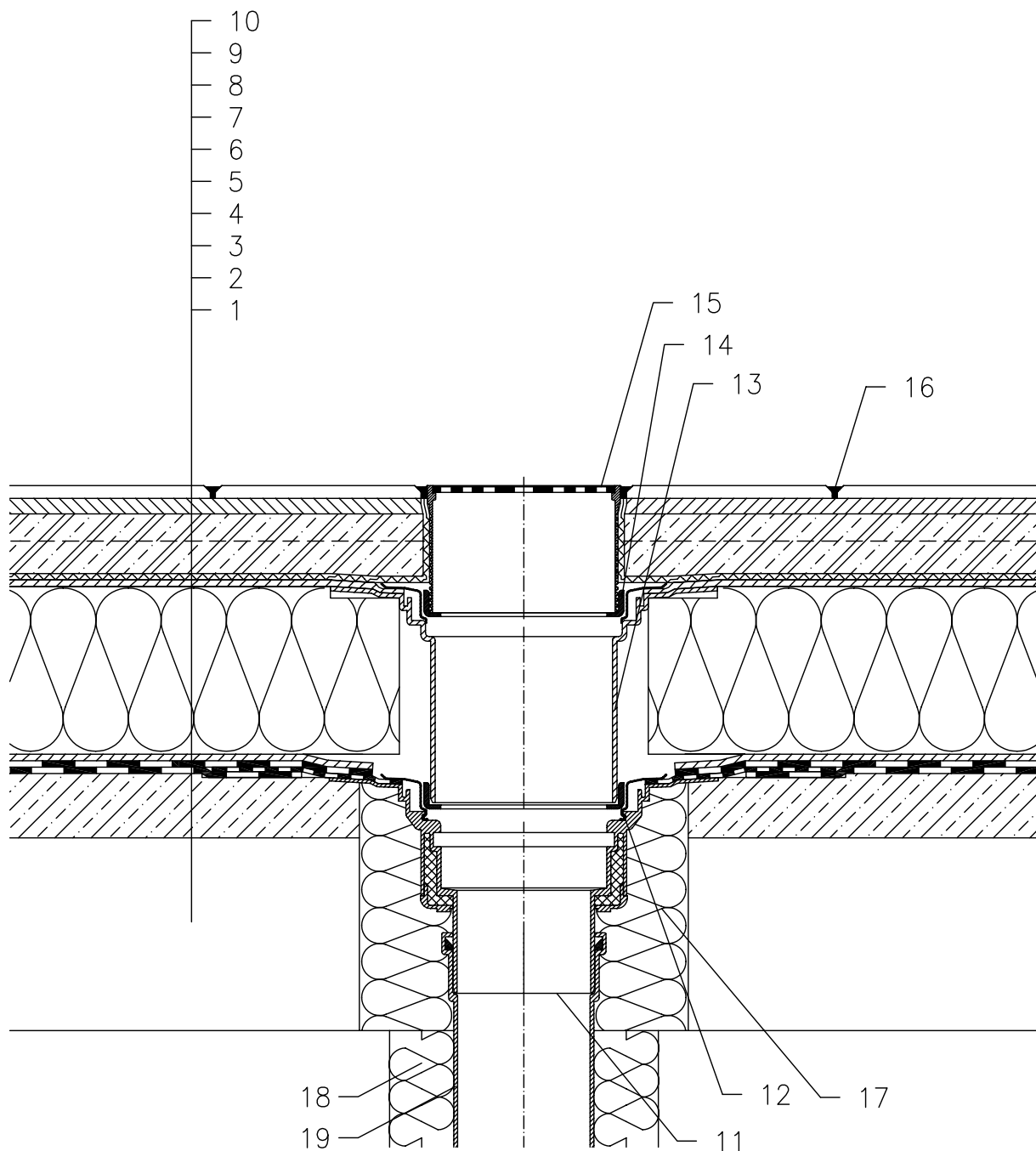

- 1 SUPPORT CONSTRUCTION
- 2 GRAVITY LAYER
- 3 BITUMEN SHEET WATERPROOFING NON-SOLID GLUED OR LAID LOOSE
- 4 DRAINAGE LAYER
- 5 THERMAL INSULATION FROM XPS
- 6 DRAINAGE LAYER
- 7 FILTER LAYER
- 8 CONCRETE SLAB
- 9 MORTAR BED OR GLUE
- 10 PAVEMENT
- 11 FLAT-ROOF DRAIN HL62BH WITH INSULATED DRAIN BODY, WITH FACTORY WELDED BITUMEN MEMBRANE  $\varnothing$ 500 mm, THICKNESS 4 mm
- 12 ADAPTER 062B.3E (INCL. WITH HL62BH)
- 13 EXTENSION HL350.1 WITH FLANGE AND WATERPROOFING KIT HL84.0
- 14 ADAPTER 062B.3E
- 15 GRATING HL66.9 WITH STAINLESS STEEL GRATE 150x150 mm CHARGEABLE TO 300 kg (INCL. WITH HL62BH)
- 16 JOINT FILLER
- 17 ASSEMBLY FOAM
- 18 DOWNPIPE THERMAL INSULATION
- 19 DOWNPIPE

NOTE:

FLAT-ROOF DRAIN HL62.1BH HEATED (230V, 10-30 WATTS) CAN BE USED.

ASSEMBLY INLET:  $\varnothing$ 220 MM, ALTERNATIVELY 240X360 MM

132111A