

ROOF WITH THERMAL INSULATION – INTENSIVE GRASSING, CLASSICAL LAYERS,
PLASTIC FOIL

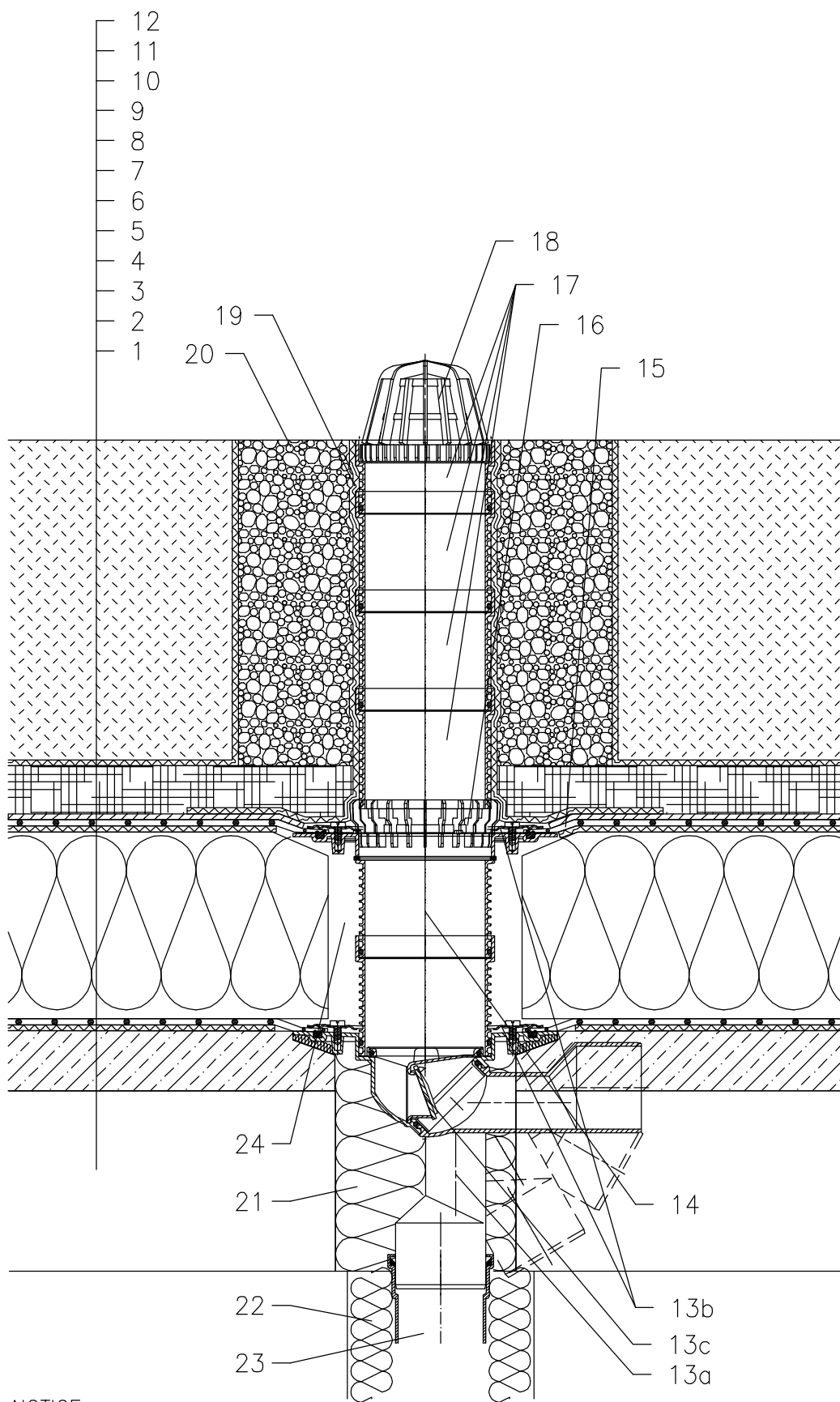

- 1 SUPPORT CONSTRUCTION
- 2 CONCRETE GRAVITY LAYER
- 3 SEPARATING AND DILATATION LAYER
- 4 MOISTURE STOP AND TEMPORARY SAFETY WATERPROOFING
- 5 THERMAL INSULATION
- 6 SEPARATING AND DILATATION LAYER
- 7 PLASTIC FOIL WATERPROOFING
- 8 SEPARATING LAYER
- 9 DRAINAGE LAYER
- 10 WATER ACCUMULATING LAYER
- 11 FILTER LAYER
- 12 VEGETATION LAYER (OVER 200mm)
- 13a DRAIN BODY HL80.3 WITH FLANGE
- 13b SEALING KIT HL83.0 – WITHOUT SHEETING,
(ALL-PURPOSE FOR UNRUFFED ROOF SHEETINGS)
(alternative HL83.P – WHEN USING PVC SHEETINGS)
- 13c FROST-PROOF FLAP HL080.4E
(NOT INCLUDED IN HL80.3)
- 14 EXTENSION HL85N WITH FLANGE
INCL. O-RING, (HL340N)
- 15 PRE-CUT PART FOR SEALING COLLAR, SEE TOPIC "ATTACHEMENTS"
- 16 DRAINAGE RING HL180
- 17 EXTENSION HL340N
- 18 LEAF STRAINER ϕ 110 mm
(INCLUDED IN HL80.3H)
- 19 SEPARATING LAYER
- 20 GRANULAR FILL
- 21 ASSEMBLY FOAM
- 22 DOWNPIPE THERMAL INSULATION
- 23 DOWNPIPE
- 24 FILL FREE SPACE WITH MINERAL WOOL

NOTICE:

TO HEAT THE DRAIN, YOU MAY USE HEATING KIT HL82 WITH SELF-REGULATING HEAT SOURCE 18W/220V. (THE HEATING TAPE MUST BE WRAPPED AROUND THE DRAIN BODY BEFORE INSTALLATION).
RECOMMENDED BOREHOLE DIAMETER IS ϕ 150mm.
DURING INSTALLATION TAKE CARE, THAT THE FLANGE POSITION IS ON THE LOWEST LEVEL OF DRAINAGE. WE RECOMMEND, TO SITE IT APPR. 1cm BELOW THE SCREED.
TO AVOID CONDENSATE WATER TAKE CARE OF THERMAL INSULATION ON THE CONSTRUCTION SITE.

122322X