

ROOF WITH THERMAL INSULATION – EXTENSIVE GRASSING, CLASSICAL LAYERS,  
PLASTIC FOIL

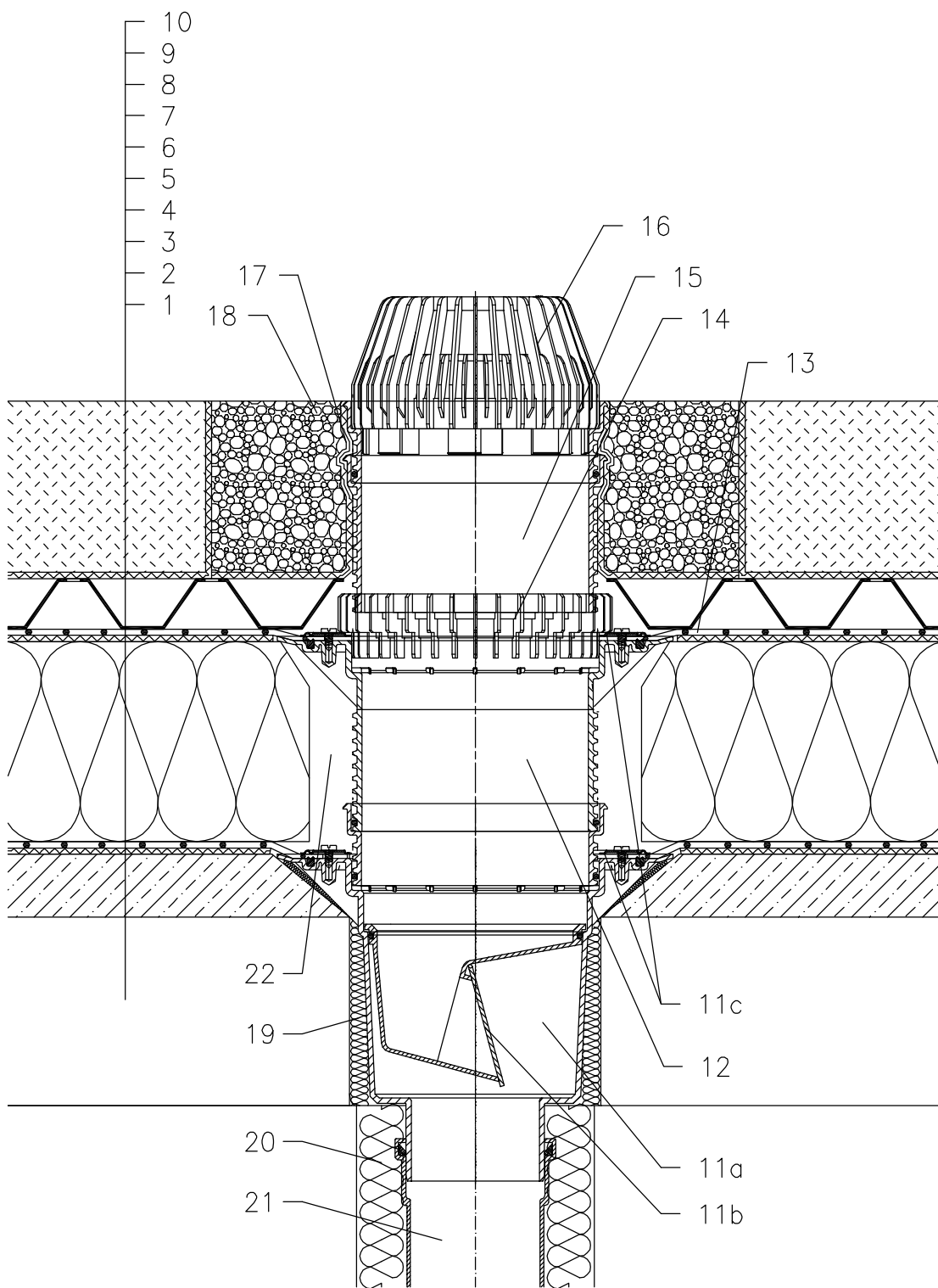

- 1 SUPPORT CONSTRUCTION
- 2 CONCRETE GRAVITY LAYER
- 3 SEPARATING AND DILATATION LAYER
- 4 MOISTURE STOP AND TEMPORARY SAFETY WATERPROOFING
- 5 THERMAL INSULATION
- 6 SEPARATING AND DILATATION LAYER
- 7 PLASTIC FOIL WATERPROOFING
- 8 WATER ACCUMULATING AND DRAINAGE LAYER
- 9 FILTER LAYER
- 10 VEGETATION LAYER (UNDER 200mm)
- 11a DRAIN BODY HL616K WITH FLANGE
- 11b FROST-PROOF FLAP HL0606.3E
- 11c SEALING KIT HL86.0 – WITHOUT SHEETING,
- 12 EXTENSION HL618 WITH FLANGE  
INCL. O-RING (HL620)
- 13 PRE-CUT PART FOR SEALING COLLAR, SEE TOPIC "ATTACHEMENTS"
- 14 DRAINAGE RING HL190
- 15 EXTENSION HL620
- 16 LEAF STRAINER HL195
- 17 SEPARATING LAYER
- 18 GRANULAR FILL
- 19 ASSEMBLY FOAM
- 20 DOWNPIPE THERMAL INSULATION
- 21 DOWNPIPE
- 22 FILL FREE SPACE WITH MINERAL WOOL

NOTICE:

TO HEAT THE DRAIN, YOU MAY USE HEATING KIT HL609 WITH SELF-REGULATING HEAT SOURCE 36W/230V. (THE HEATING TAPE MUST BE WRAPPED AROUND THE DRAIN BODY BEFORE INSTALLATION).  
RECOMMENDED BOREHOLE DIAMETER IS  $\varnothing 220\text{mm}$ , WITH HEATING KIT MIN.  $\varnothing 240\text{mm}$   
DURING INSTALLATION TAKE CARE, THAT THE FLANGE POSITION IS ON THE LOWEST LEVEL OF DRAINAGE. WE RECOMMEND, TO SITE IT APPR. 1cm BELOW THE SCREED.  
TO AVOID CONDENSATE WATER TAKE CARE OF THERMAL INSULATION ON THE CONSTRUCTION SITE.

122312Y