

WARM ROOF – GREEN ROOF, CLASSICAL STRUCTURE, PLASTIC FOIL WATERPROOFING
EXTENSIVE GRASSING

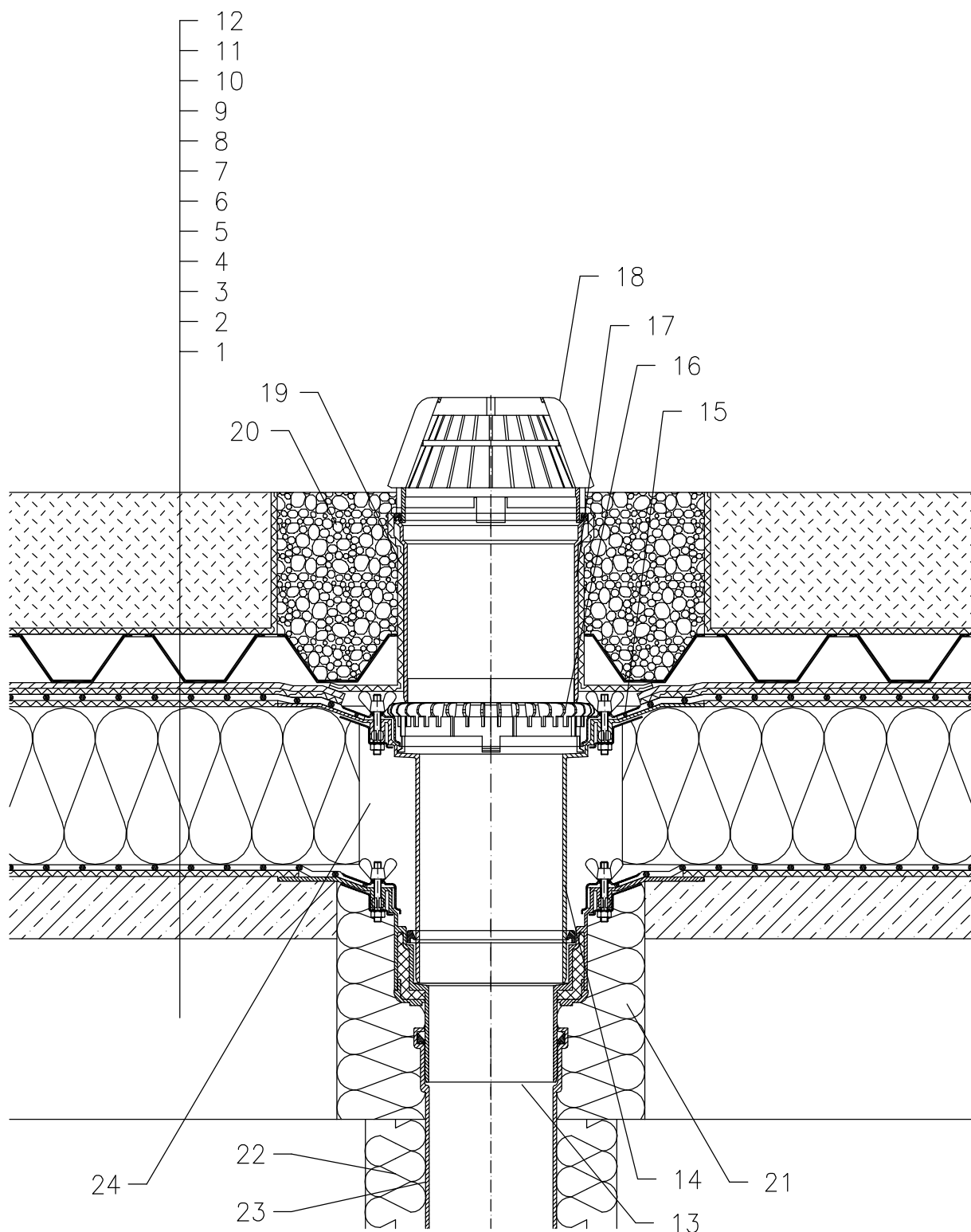

- 1 SUPPORT CONSTRUCTION
- 2 GRAVITY LAYER
- 3 DILATATION LAYER
- 4 MOISTURE STOP AND TEMPORARY SAFETY WATERPROOFING FROM PLASTIC FOIL
- 5 THERMAL INSULATION
- 6 DILATATION LAYER
- 7 PLASTIC FOIL WATERPROOFING WITH FLL CERTIFICATE LAID LOOSE
- 8 DILATATION LAYER
- 9 DRAINAGE LAYER
- 10 WATER ACCUMULATING LAYER
- 11 FILTER LAYER
- 12 VEGETATION LAYER (UNDER 200 mm)
- 13 FLAT-ROOF DRAIN HL62 WITH INSULATED DRAIN BODY, FLANGE AND STAINLESS STEEL CLAMPING RING
- 14 EXTENSION HL65 WITH FLANGE, STAINLESS STEEL CLAMPING RING AND LIP SEAL
- 15 SEALING PACKING (SEE DETAIL-ACCESSORIES)
- 16 GRAVEL GUARD HL160
- 17 EXTENSION HL350
- 18 DOMED PLASTIC GRATE \varnothing 180 mm (INCL. WITH HL62)
- 19 SEPARATING LAYER
- 20 GRANULAR FILL
- 21 ASSEMBLY FOAM
- 22 DOWNPIPE THERMAL INSULATION
- 23 DOWNPIPE
- 24 FILL FREE SPACE WITH MINERAL WOOL

NOTE:

FLAT-ROOF DRAIN HL62.1 HEATED (230V, 10-30 WATTS) CAN BE USED.

ASSEMBLY INLET: \varnothing 220 MM, ALTERNATIVELY 240X360 MM