

ROOF WITH THERMAL INSULATION – EXTENSIVE GRASSING, CLASSICAL LAYERS,  
BITUMEN SHEETS

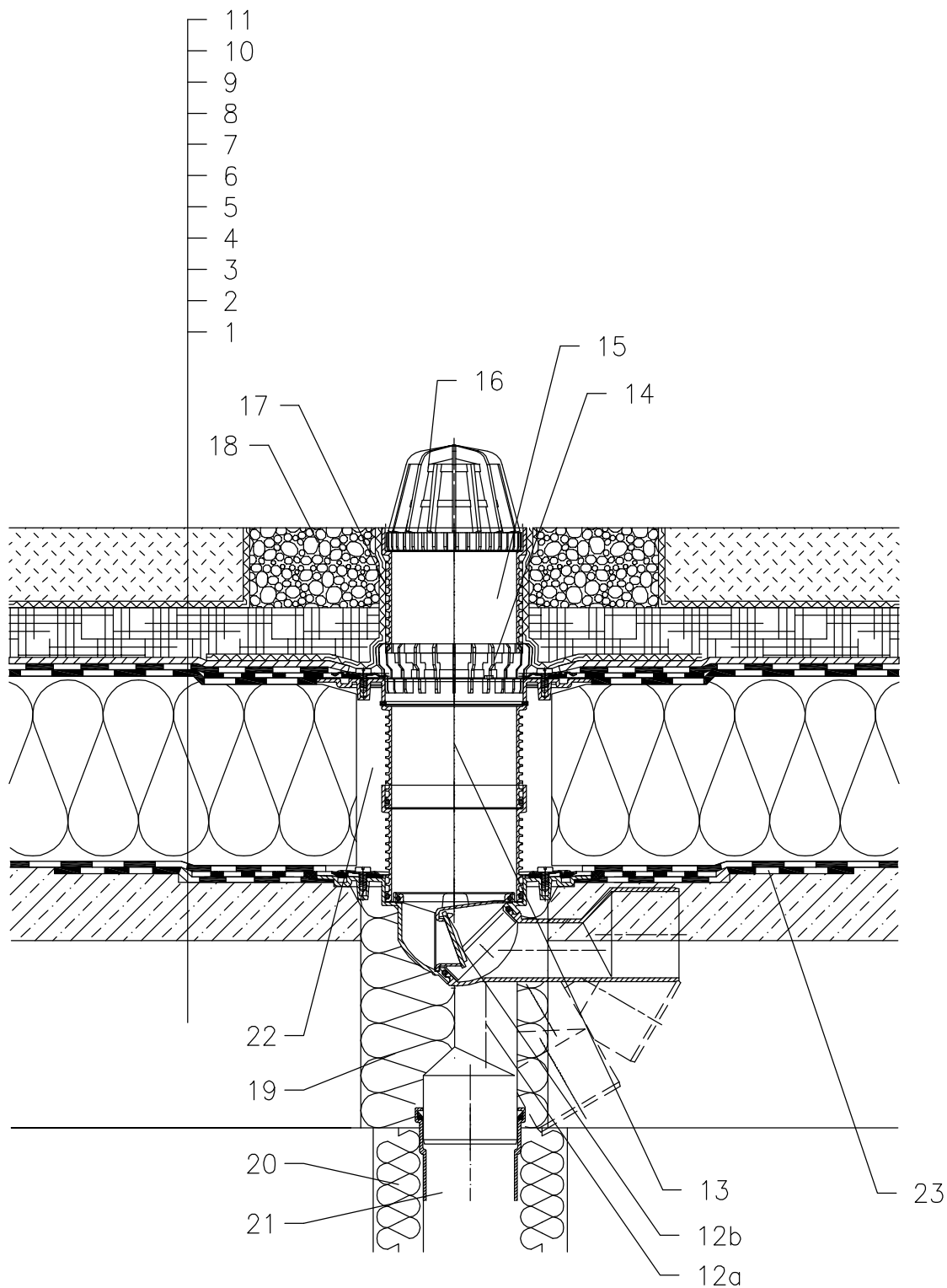

- 1 SUPPORT CONSTRUCTION
- 2 CONCRETE GRAVITY LAYER
- 3 MOISTURE STOP AND TEMPORARY SAFETY WATERPROOFING FROM BITUMEN SHEET
- 4 THERMAL INSULATION
- 5 BITUMEN SHEET WATERPROOFING NON SOLID GLUED OR LAID LOOSE
- 6 BITUMEN SHEET WATERPROOFING
- 7 SEPARATING LAYER
- 8 DRAINAGE LAYER
- 9 WATER ACCUMULATING LAYER
- 10 FILTER LAYER
- 11 VEGETATION LAYER (UNDER 200mm)
- 12a ROOF DRAIN HL80.3H WITH BITUMEN MEMBRANE  $\phi$ 400 mm
- 12b FROST-PROOF FLAP HL080.4E (NOT INCLUDED IN HL80.3H)
- 13 EXTENSION HL85NH WITH BITUMEN MEMBRANE  $\phi$ 400 mm; INCL. O-RING, (HL340N)
- 14 DRAINAGE RING HL180
- 15 EXTENSION HL340N
- 16 LEAF STRAINER  $\phi$ 110 mm (INCLUDED IN HL80.3H)
- 17 SEPARATING LAYER
- 18 GRANULAR FILL
- 19 ASSEMBLY FOAM
- 20 DOWNPIPE THERMAL INSULATION
- 21 DOWNPIPE
- 22 FILL FREE SPACE WITH MINERAL WOOL
- 23 BITUMEN MEMBRANE  $\phi$ 750 mm

NOTICE:

TO HEAT THE DRAIN, YOU MAY USE HEATING KIT HL82 WITH SELF-REGULATING HEAT SOURCE 18W/220V. (THE HEATING TAPE MUST BE WRAPPED AROUND THE DRAIN BODY BEFORE INSTALLATION).  
RECOMMENDED BOREHOLE DIAMETER IS  $\phi$ 150mm.  
DURING INSTALLATION TAKE CARE, THAT THE FLANGE POSITION IS ON THE LOWEST LEVEL OF DRAINAGE. WE RECOMMEND, TO SITE IT APPR. 1cm BELOW THE SCREED.  
TO AVOID CONDENSATE WATER TAKE CARE OF THERMAL INSULATION ON THE CONSTRUCTION SITE.

122311AX