

WARM ROOF – CAR PARK, CLASSICAL COMPACT STRUCTURE, BITUMEN SHEET WATERPROOFING

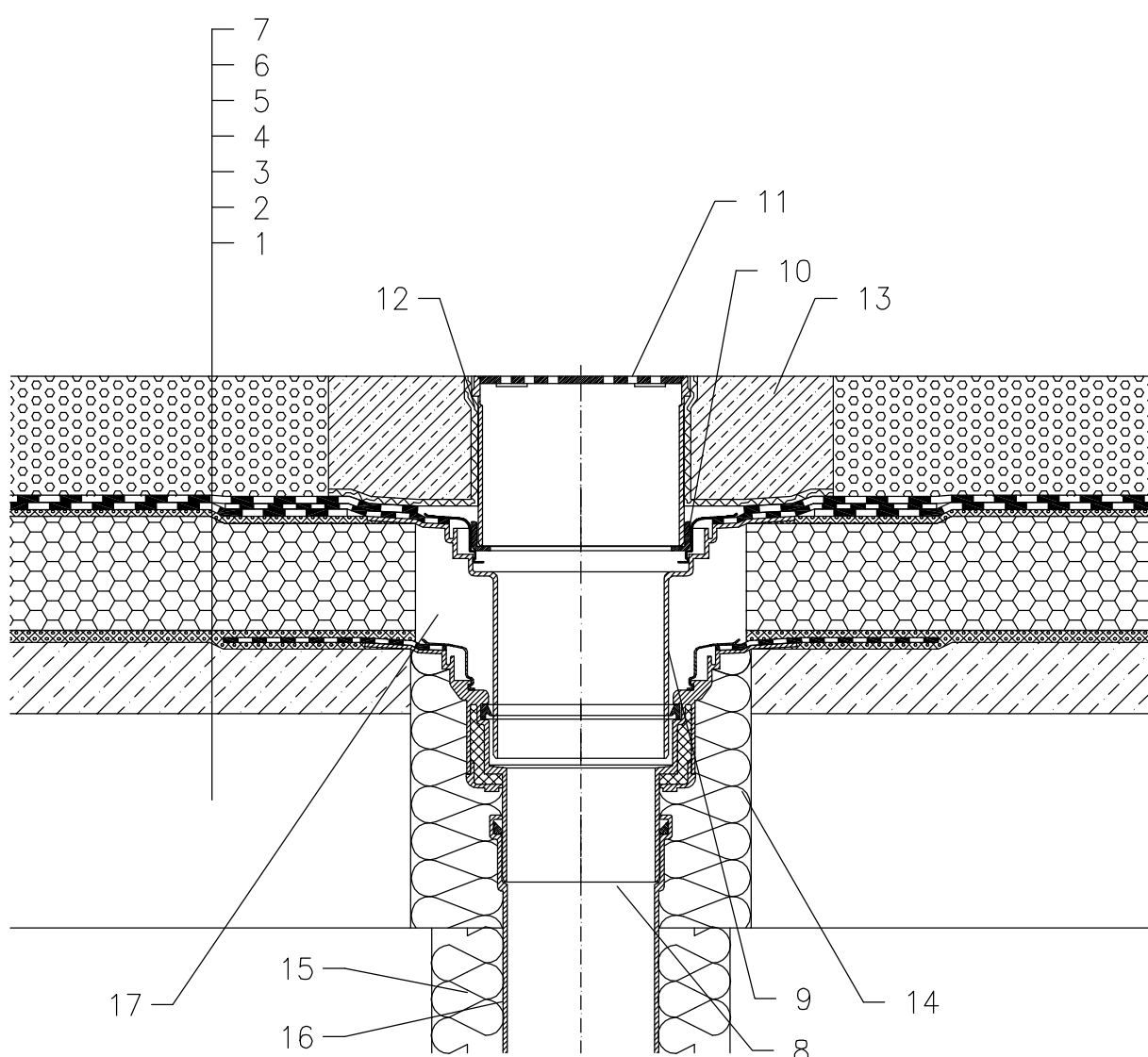

- 1 SUPPORT CONSTRUCTION
- 2 GRAVITY LAYER
- 3 HOT BITUMEN
- 4 THERMAL INSULATION – CELLULAR GLASS
- 5 HOT BITUMEN
- 6 BITUMEN SHEET WATERPROOFING SOLID GLUED
- 7 CAST ASPHALT
- 8 FLAT-ROOF DRAIN HL62H WITH INSULATED DRAIN BODY, WITH FACTORY WELDED BITUMEN MEMBRANE  $\varnothing$ 500 mm, THICKNESS 4 mm
- 9 EXTENSION HL65H WITH FLANGE AND FACTORY WELDED WITH FACTORY WELDED BITUMEN MEMBRANE  $\varnothing$ 500 mm, THICKNESS 4 mm
- 10 ADAPTER 062B.3E
- 11 GRATING HL66 (TRUNCATABLE) WITH STAINLESS STEEL FRAME AND SECURED STAINLESS STEEL GRATE, MAX. LOAD 1,5 t
- 12 DILATATION LAYER
- 13 CONCRETE BELT 1000 X 1000 X 100 mm
- 14 ASSEMBLY FOAM
- 15 DOWNPIPE THERMAL INSULATION
- 16 DOWNPIPE
- 17 FILL FREE SPACE WITH MINERAL WOOL

NOTE:

FLAT-ROOF DRAIN HL62.1H HEATED (230V, 10-30 WATTS) CAN BE USED.

ASSEMBLY INLET:  $\varnothing$ 220 MM, ALTERNATIVELY 240X360 MM