

## ROOF WITH THERMAL INSULATION – CAR PARK, CLASSICAL LAYERS, PLASTIC FOIL

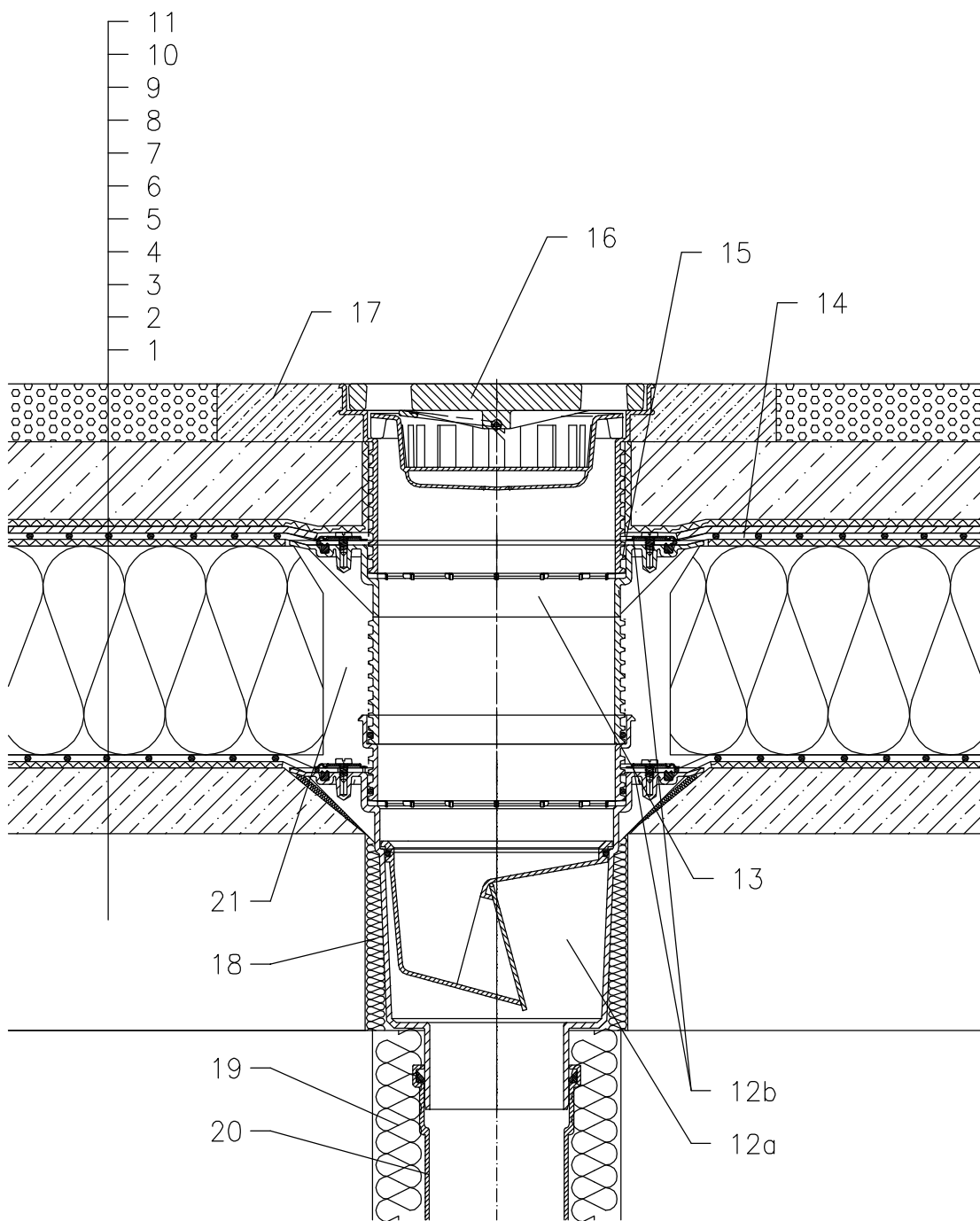

- 1 SUPPORT CONSTRUCTION
- 2 CONCRETE GRAVITY LAYER
- 3 SEPARATING AND DILATATION LAYER
- 4 MOISTURE STOP AND TEMPORARY SAFETY WATERPROOFING
- 5 THERMAL INSULATION
- 6 SEPARATING AND DILATATION LAYER
- 7 PLASTIC FOIL WATERPROOFING
- 8 DRAINAGE LAYER
- 9 FILTER LAYER
- 10 REINFORCED CONCRETE
- 11 CAST ASPHALT
- 12a TERRACE DRAIN HL616 WITH FROST-PROOF FLAP AND FLANGE  
LOAD CLASSIFICATION L15 (MAX 1500 kg)  
alternative DRAIN HL616.1, LOAD CLASSIFICATION M125 (MAX 12,5 t)
- 12b SEALING KIT HL86.0 – WITHOUT SHEETING,
- 13 EXTENSION HL618 WITH FLANGE  
INCL. O-RING (HL620)
- 14 PRE-CUT PART FOR SEALING COLLAR, SEE TOPIC "ATTACHEMENTS"
- 15 NO TIGHT CONNECTION BECAUSE OF DISCHARGE OF LEAKAGE WATER
- 16 EXTENSION WITH CAST IRON GRATE 226x226 mm  
AND PLASTIC FRAME 240x240 mm  
(INCLUDED IN HL616)
- 17 CONCRETE 1000x1000x100 mm
- 18 ASSEMBLY FOAM
- 19 DOWNPIPE THERMAL INSULATION
- 20 DOWNPIPE
- 21 FILL FREE SPACE WITH MINERAL WOOL

### NOTICE:

TO HEAT THE DRAIN, YOU MAY USE HEATING KIT HL609 WITH SELF-REGULATING HEAT SOURCE 36W/230V. (THE HEATING TAPE MUST BE WRAPPED AROUND THE DRAIN BODY BEFORE INSTALLATION).  
RECOMMENDED BOREHOLE DIAMETER IS  $\phi 220\text{mm}$ , WITH HEATING KIT MIN.  $\phi 240\text{mm}$   
DURING INSTALLATION TAKE CARE, THAT THE FLANGE POSITION IS ON THE LOWEST LEVEL OF DRAINAGE. WE RECOMMEND, TO SITE IT APPR. 1cm BELOW THE SCREED.  
TO AVOID CONDENSATE WATER TAKE CARE OF THERMAL INSULATION ON THE CONSTRUCTION SITE.

122212Y