

WARM ROOF – CAR PARK, CLASSICAL STRUCTURE, PLASTIC FOIL WATERPROOFING

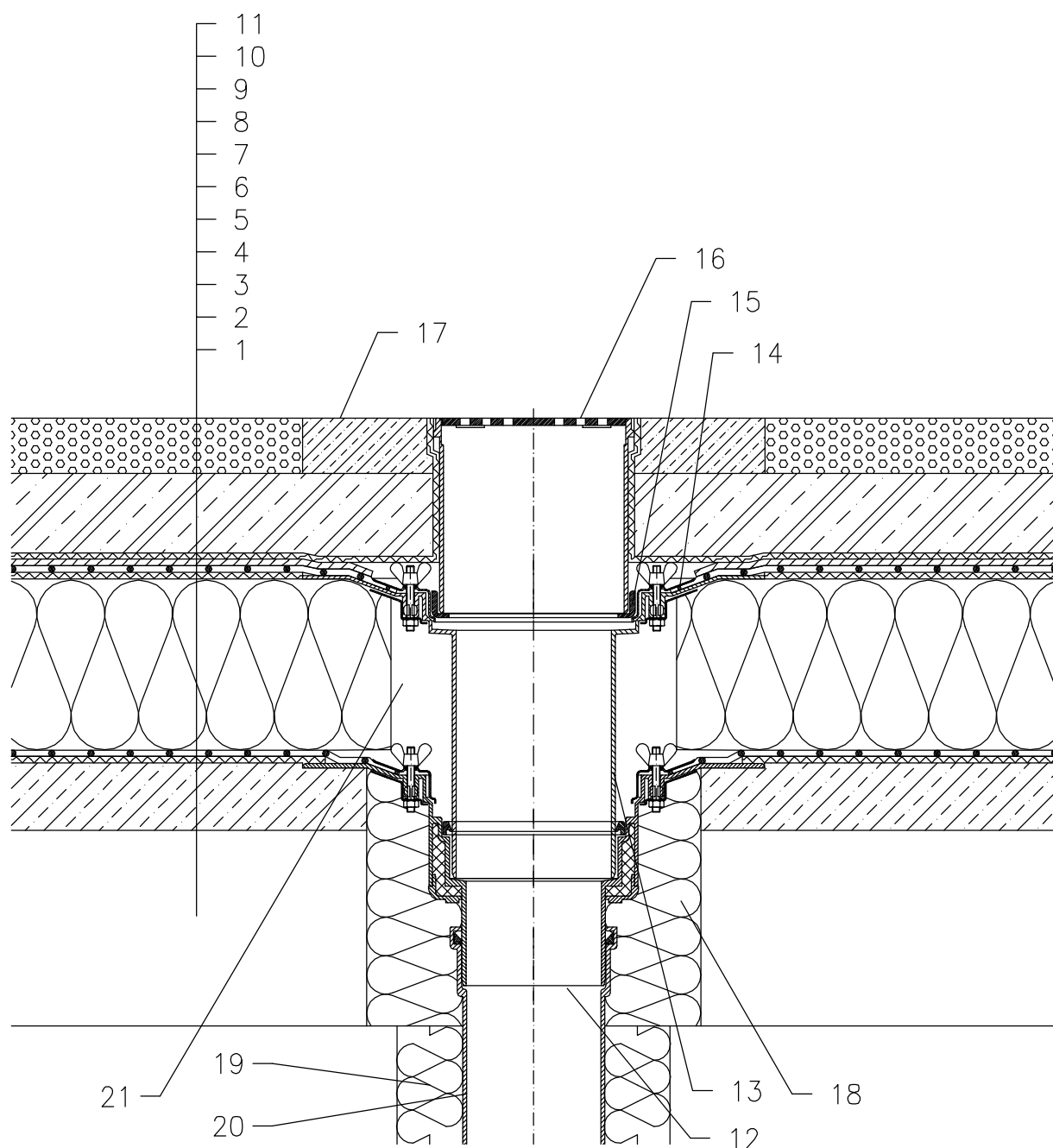

- 1 SUPPORT CONSTRUCTION
- 2 GRAVITY LAYER
- 3 DILATATION LAYER
- 4 MOISTURE STOP AND TEMPORARY SAFETY WATERPROOFING FROM PLASTIC FOIL
- 5 THERMAL INSULATION
- 6 DILATATION LAYER
- 7 PLASTIC FOIL WATERPROOFING LAID LOOSE
- 8 DRAINAGE LAYER
- 9 FILTER LAYER
- 10 REINFORCED CONCRETE SLAB
- 11 CAST ASPHALT
- 12 FLAT-ROOF DRAIN HL62 WITH INSULATED DRAIN BODY, FLANGE AND STAINLESS STEEL CLAMPING RING
- 13 EXTENSION HL65 WITH FLANGE, STAINLESS STEEL CLAMPING RING AND LIP SEAL
- 14 SEALING PACKING (SEE DETAIL-ACCESSORIES)
- 15 ADAPTER 062B.3E
- 16 GRATING HL66 (TRUNCATABLE) WITH STAINLESS STEEL FRAME AND SECURED STAINLESS STEEL GRATE, MAX. LOAD 1,5 t
- 17 CONCRETE BELT 1000 X 1000 X 100 mm
- 18 ASSEMBLY FOAM
- 19 DOWNPIPE THERMAL INSULATION
- 20 DOWNPIPE
- 21 FILL FREE SPACE WITH MINERAL WOOL

NOTE:

FLAT-ROOF DRAIN HL62.1 HEATED (230V, 10-30 WATTS) CAN BE USED.

ASSEMBLY INLET:  $\varnothing$ 220 MM, ALTERNATIVELY 240X360 MM