

ROOF WITH THERMAL INSULATION – CLASSICAL LAYERS, PLASTIC FOIL  
TERRACE, PAVEMENT IN SUBBASE

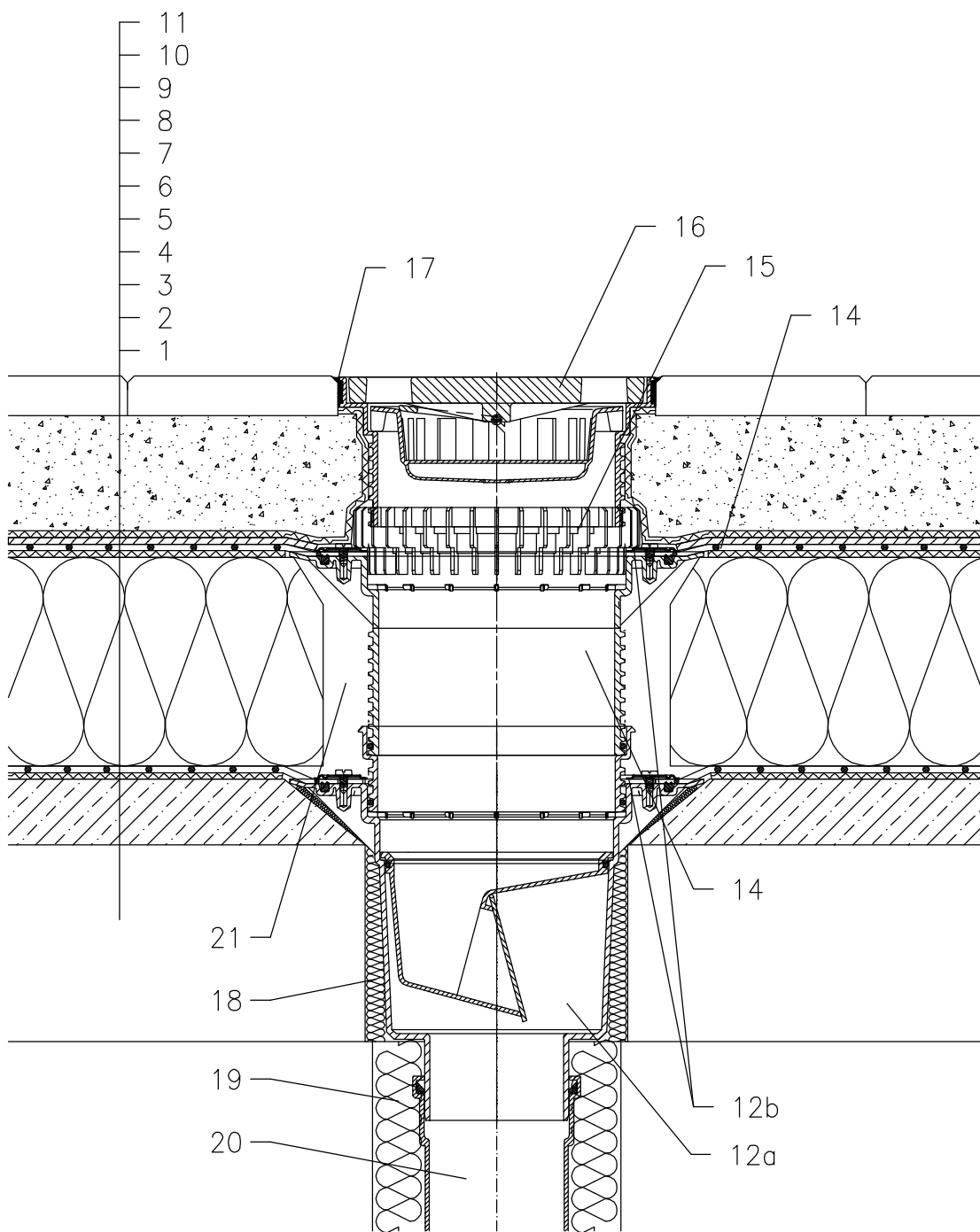

- 1 SUPPORT CONSTRUCTION
- 2 CONCRETE GRAVITY LAYER
- 3 SEPARATING AND DILATATION LAYER
- 4 MOISTURE STOP AND TEMPORARY SAFETY WATERPROOFING
- 5 THERMAL INSULATION
- 6 SEPARATING AND DILATATION LAYER
- 7 PLASTIC FOIL WATERPROOFING
- 8 DRAINAGE LAYER
- 9 FILTER LAYER
- 10 SAND SUBBASE
- 11 PAVEMENT
- 12a TERRACE DRAIN HL616 WITH FROST-PROOF FLAP AND FLANGE  
LOAD CLASSIFICATION L15 (MAX 1500 kg)
- 12b SEALING KIT HL86.0 – WITHOUT SHEETING,
- 13 EXTENSION HL618 WITH FLANGE  
INCL. O-RING (HL620)
- 14 PRE-CUT PART FOR SEALING COLLAR, SEE TOPIC "ATTACHEMENTS"
- 15 DRAINAGE RING HL190
- 16 EXTENSION WITH CAST IRON GRATE 226x226 mm  
AND PLASTIC FRAME 240x240 mm  
(INCLUDED IN HL616)  
alternative HL616S – WITH STAINLESS STEEL GRATE  
alternative HL616L – WITH PLASTIC GRATE
- 17 JOINT FILLER
- 18 ASSEMBLY FOAM
- 19 DOWNPIPE THERMAL INSULATION
- 20 DOWNPIPE
- 21 FILL FREE SPACE WITH MINERAL WOOL

NOTICE:

TO HEAT THE DRAIN, YOU MAY USE HEATING KIT HL609 WITH SELF-REGULATING HEAT SOURCE 36W/230V. (THE HEATING TAPE MUST BE WRAPPED AROUND THE DRAIN BODY BEFORE INSTALLATION).  
RECOMMENDED BOREHOLE DIAMETER IS  $\varnothing 220\text{mm}$ , WITH HEATING KIT MIN.  $\varnothing 240\text{mm}$   
DURING INSTALLATION TAKE CARE, THAT THE FLANGE POSITION IS ON THE LOWEST LEVEL OF DRAINAGE. WE RECOMMEND, TO SITE IT APPR. 1cm BELOW THE SCREED.  
TO AVOID CONDENSATE WATER TAKE CARE OF THERMAL INSULATION ON THE CONSTRUCTION SITE.

122122Y