

ROOF WITH THERMAL INSULATION – CLASSICAL LAYERS, PLASTIC FOIL  
TERRACE, PAVEMENT IN SUBBASE

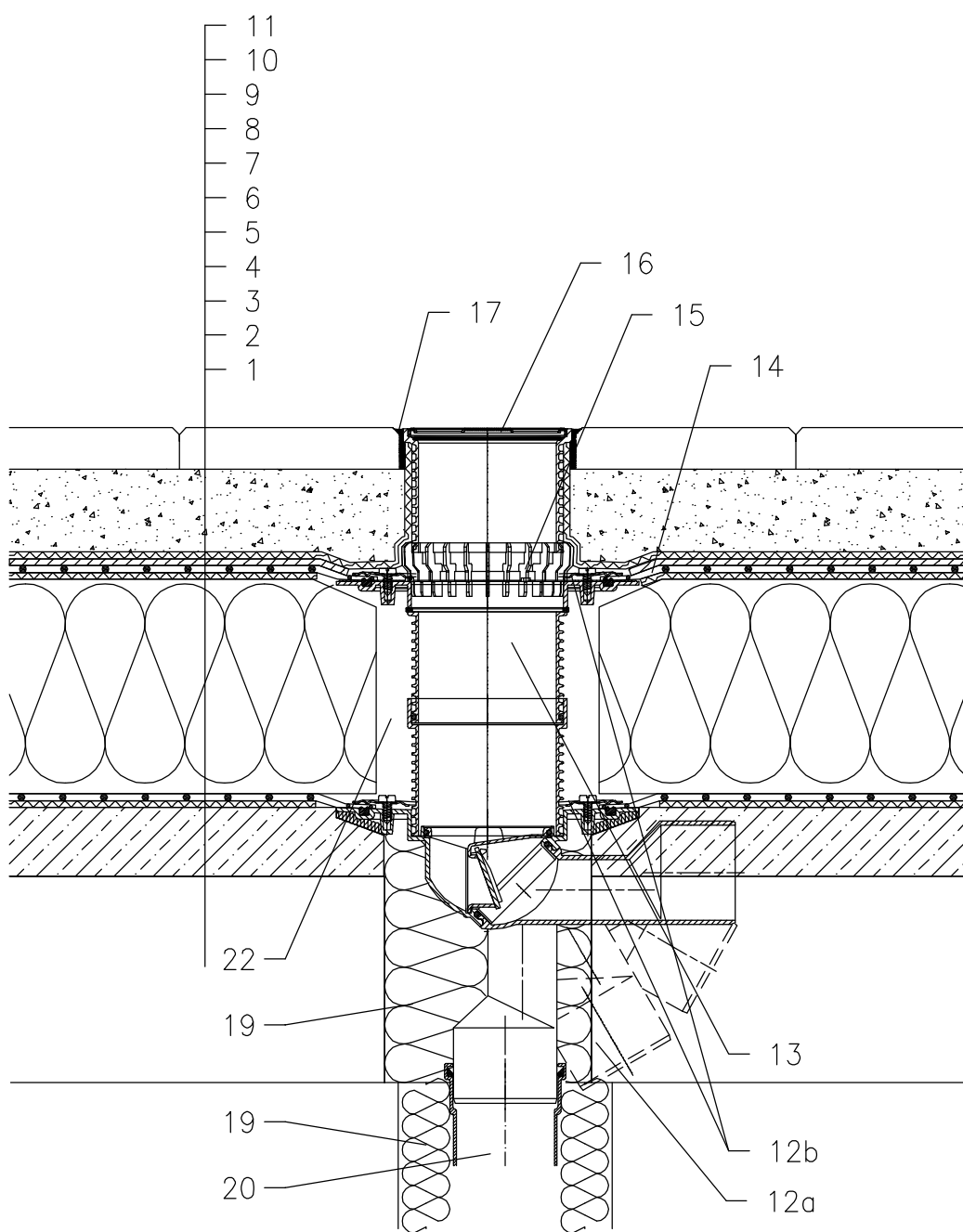

- 1 SUPPORT CONSTRUCTION
- 2 CONCRETE GRAVITY LAYER
- 3 SEPARATING AND DILATATION LAYER
- 4 MOISTURE STOP AND TEMPORARY SAFETY WATERPROOFING
- 5 THERMAL INSULATION
- 6 SEPARATING AND DILATATION LAYER
- 7 PLASTIC FOIL WATERPROOFING
- 8 DRAINAGE LAYER
- 9 FILTER LAYER
- 10 SAND SUBBASE
- 11 PAVEMENT
- 12a TERRACE DRAIN HL80 WITH FROST-PROOF FLAP AND FLANGE  
LOAD CLASSIFICATION K3 (MAX 300 kg)
- 12b SEALING KIT HL83.0 – WITHOUT SHEETING,  
(ALL-PURPOSE FOR UNRUFFED ROOF SHEETINGS)  
(alternative HL83.P – WHEN USING PVC SHEETINGS)
- 13 EXTENSION HL85N WITH FLANGE  
INCL. O-RING, (HL340N)
- 14 PRE-CUT PART FOR SEALING COLLAR, SEE TOPIC "ATTACHEMENTS"
- 15 DRAINAGE RING HL180
- 16 EXTENSION WITH STAINLESS STEEL GRATE 115x115 mm  
AND PLASTIC FRAME 123x123 mm  
(INCLUDED IN HL80)
- 17 NON-HARDENING MASTIC
- 18 ASSEMBLY FOAM
- 19 DOWNPIPE THERMAL INSULATION
- 20 DOWNPIPE
- 21 FILL FREE SPACE WITH MINERAL WOOL

NOTICE:

TO HEAT THE DRAIN, YOU MAY USE HEATING KIT HL82 WITH SELF-REGULATING HEAT SOURCE 18W/220V. (THE HEATING TAPE MUST BE WRAPPED AROUND THE DRAIN BODY BEFORE INSTALLATION).  
RECOMMENDED BOREHOLE DIAMETER IS  $\varnothing 150\text{mm}$ .  
DURING INSTALLATION TAKE CARE, THAT THE FLANGE POSITION IS ON THE LOWEST LEVEL OF DRAINAGE. WE RECOMMEND, TO SITE IT APPR. 1cm BELOW THE SCREED.  
TO AVOID CONDENSATE WATER TAKE CARE OF THERMAL INSULATION ON THE CONSTRUCTION SITE.

122122X