

ROOF WITH THERMAL INSULATION – CLASSICAL LAYERS, BITUMEN SHEETS
TERRACE, PAVEMENT IN CONCRETE, WITH THINBED WATERPROOFING AND DRAINAGE MAT

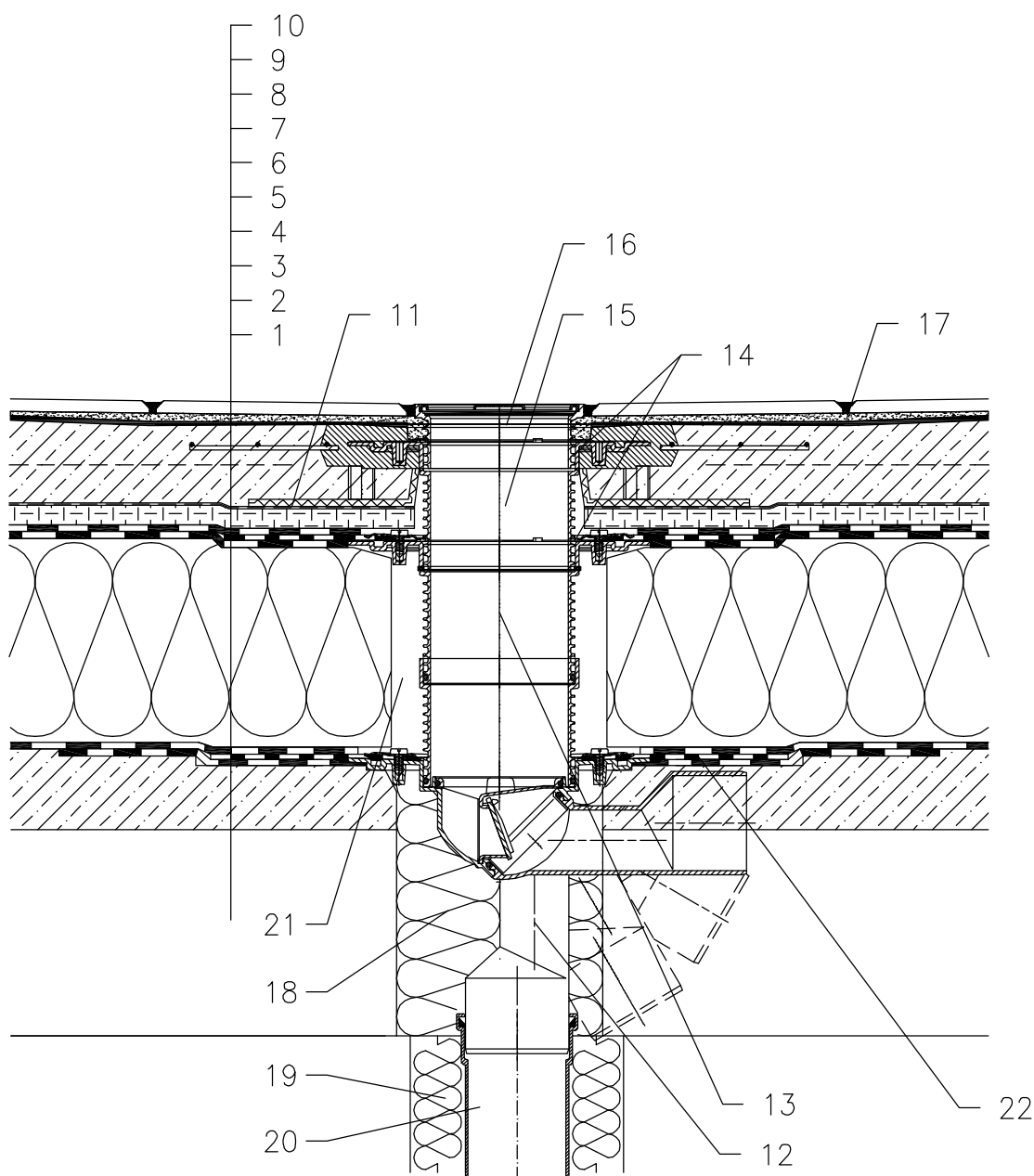

- 1 SUPPORT CONSTRUCTION
- 2 CONCRETE GRAVITY LAYER
- 3 MOISTURE STOP AND TEMPORARY SAFETY WATERPROOFING FROM BITUMEN SHEET
- 4 THERMAL INSULATION
- 5 BITUMEN SHEET WATERPROOFING NON SOLID GLUED OR LAID LOOSE
- 6a BITUMEN SHEET WATERPROOFING
- 6b SEPARATING LAYER
- 7 DRAINAGE LAYER AND SEPARATING LAYER for example: DRAINAGE MAT AquaDrain FE+
- 8 FILTER LAYER
- 9 THINBED WATERPROOFING
- 10 PAVEMENT EMBEDDED IN CONCRETE
- 11 SEPARATING LAYER
- 12 TERRACE DRAIN HL80H WITH FROST-PROOF FLAP AND BITUMEN MEMBRANE WITH BITUMEN MEMBRANE $\phi 400$ mm, LOAD CLASSIFICATION K3 (MAX 300 kg)
- 13 EXTENSION HL85NH WITH BITUMEN MEMBRANE WITH BITUMEN MEMBRANE $\phi 400$ mm; INCL. O-RING
- 14 NO TIGHT CONNECTION BECAUSE OF DISCHARGE OF LEAKAGE WATER
- 15 EXTENSION HL85NC WITH POLYMER CONCRETE COLLAR AND GLASS FIBRE MAT
- 16 EXTENSION WITH STAINLESS STEEL GRATE 115x115 mm AND PLASTIC FRAME 123x123 mm (INCLUDED IN HL80H)
- 17 JOINT FILLER
- 18 ASSEMBLY FOAM
- 19 DOWNPIPE THERMAL INSULATION
- 20 DOWNPIPE
- 21 FILL FREE SPACE WITH MINERAL WOOL
- 22 BITUMEN MEMBRANE $\phi 750$ mm

NOTICE:

TO HEAT THE DRAIN, YOU MAY USE HEATING KIT HL82 WITH SELF-REGULATING HEAT SOURCE 18W/220V. (THE HEATING TAPE MUST BE WRAPPED AROUND THE DRAIN BODY BEFORE INSTALLATION).

RECOMMENDED BOREHOLE DIAMETER IS $\phi 150$ mm.

DURING INSTALLATION TAKE CARE, THAT THE FLANGE POSITION IS ON THE LOWEST LEVEL OF DRAINAGE. WE RECOMMEND, TO SITE IT APPR. 1cm BELOW THE SCREED.

TO AVOID CONDENSATE WATER TAKE CARE OF THERMAL INSULATION ON THE CONSTRUCTION SITE.

122113BXD