

ROOF WITH THERMAL INSULATION – CLASSICAL LAYERS, PLASTIC FOIL
TERRACE, PAVEMENT IN CONCRETE

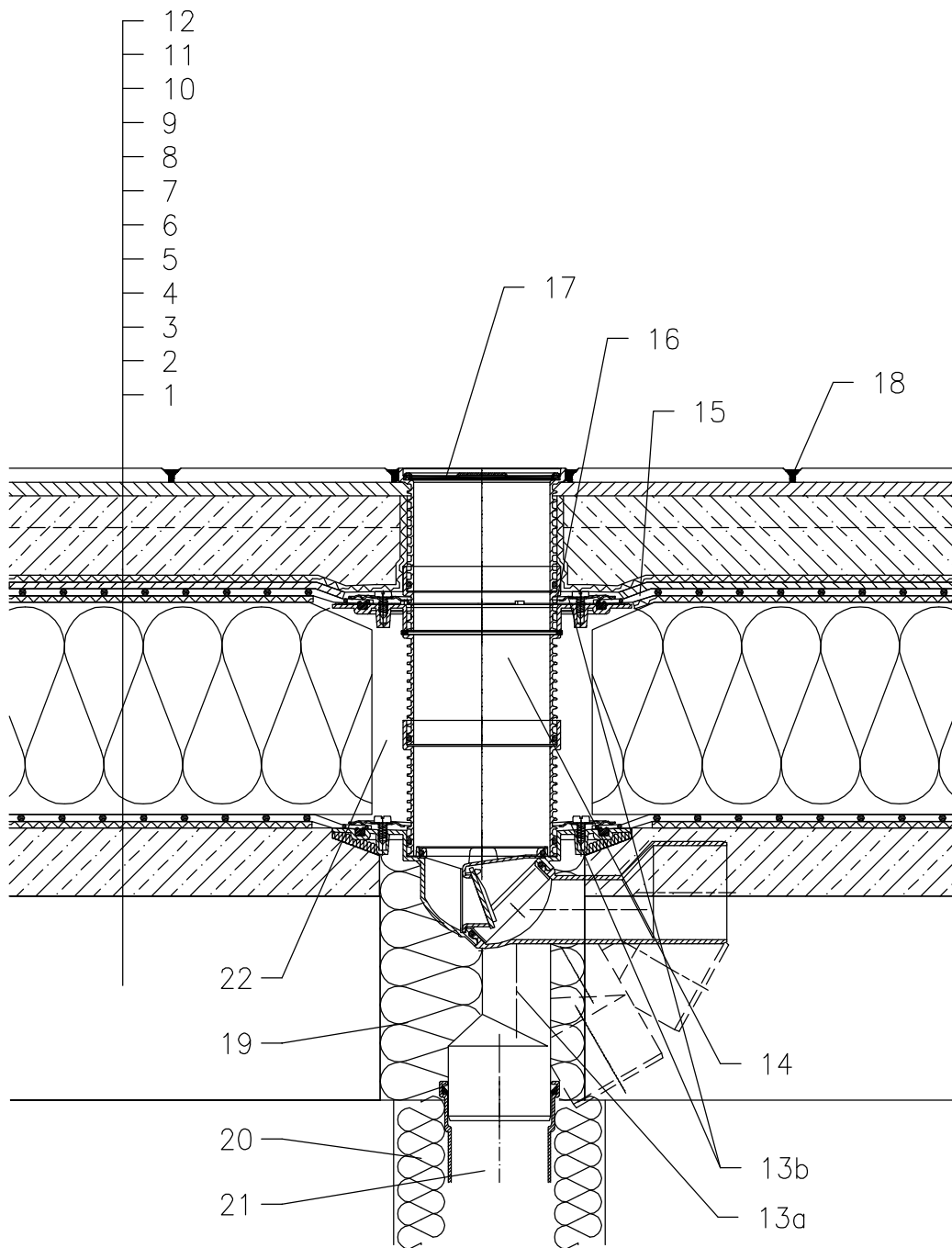

- 1 SUPPORT CONSTRUCTION
- 2 CONCRETE GRAVITY LAYER
- 3 SEPARATING AND DILATATION LAYER
- 4 MOISTURE STOP AND TEMPORARY SAFETY WATERPROOFING
- 5 THERMAL INSULATION
- 6 SEPARATING AND DILATATION LAYER
- 7 PLASTIC FOIL WATERPROOFING
- 8 DRAINAGE LAYER
- 9 FILTER LAYER
- 10 CONCRETE SLAB
- 11 MORTAR BED OR GLUE
- 12 PAVEMENT
- 13a TERRACE DRAIN HL80 WITH FROST-PROOF FLAP AND FLANGE
LOAD CLASSIFICATION K3 (MAX 300 kg)
- 13b SEALING KIT HL83.0 – WITHOUT SHEETING, (ALL-PURPOSE FOR UNRUFFED ROOF SHEETINGS)
(alternative HL83.P – WHEN USING PVC SHEETINGS)
- 14 EXTENSION HL85N WITH FLANGE INCL. O-RING, (HL340N)
- 15 PRE-CUT PART FOR SEALING COLLAR, SEE TOPIC "ATTACHEMENTS"
- 16 NO TIGHT CONNECTION BECAUSE OF DISCHARGE OF LEAKAGE WATER
- 17 EXTENSION WITH STAINLESS STEEL GRATE 115x115 mm AND PLASTIC FRAME 123x123 mm (INCLUDED IN HL80)
- 18 JOINT FILLER
- 19 ASSEMBLY FOAM
- 20 DOWNPIPE THERMAL INSULATION
- 21 DOWNPIPE
- 22 FILL FREE SPACE WITH MINERAL WOOL

NOTICE:

TO HEAT THE DRAIN, YOU MAY USE HEATING KIT HL82 WITH SELF-REGULATING HEAT SOURCE 18W/220V. (THE HEATING TAPE MUST BE WRAPPED AROUND THE DRAIN BODY BEFORE INSTALLATION).
RECOMMENDED BOREHOLE DIAMETER IS $\phi 150\text{mm}$.
DURING INSTALLATION TAKE CARE, THAT THE FLANGE POSITION IS ON THE LOWEST LEVEL OF DRAINAGE. WE RECOMMEND, TO SITE IT APPR. 1cm BELOW THE SCREED.
TO AVOID CONDENSATE WATER TAKE CARE OF THERMAL INSULATION ON THE CONSTRUCTION SITE.

122112X