

WARM ROOF – WALKABLE, CLASSICAL STRUCTURE, BITUMEN SHEET WATERPROOFING  
PAVEMENT GLUED

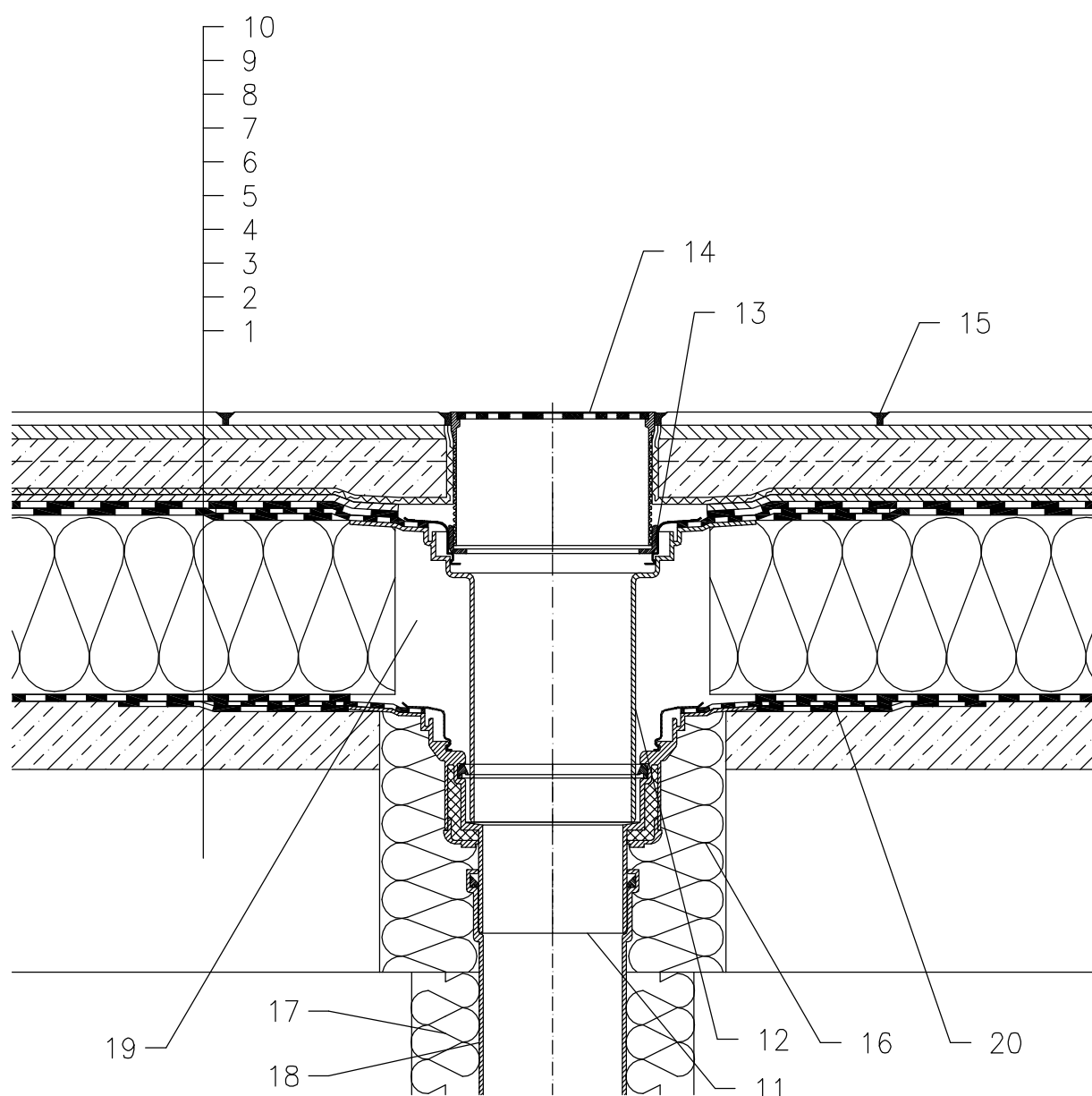

- 1 SUPPORT CONSTRUCTION
- 2 GRAVITY LAYER
- 3 MOISTURE STOP AND TEMPORARY SAFETY WATERPROOFING FROM BITUMEN SHEET
- 4 THERMAL INSULATION
- 5 BITUMEN SHEET WATERPROOFING NON-SOLID GLUED OR LAID LOOSE
- 6 DRAINAGE LAYER
- 7 FILTER LAYER
- 8 CONCRETE SLAB
- 9 MORTAR BED OR GLUE
- 10 PAVEMENT
- 11 FLAT-ROOF DRAIN HL62BH WITH INSULATED DRAIN BODY, WITH FACTORY WELDED BITUMEN MEMBRANE  $\phi$ 500 mm, THICKNESS 4 mm
- 12 EXTENSION HL65H WITH FLANGE AND FACTORY WELDED BITUMEN MEMBRANE  $\phi$ 500 mm, THICKNESS 4 mm
- 13 ADAPTER 062B.3E (INCL. WITH HL62BH)
- 14 GRATING HL66.9 WITH STAINLESS STEEL GRATE 150x150 mm CHARGEABLE TO 300 kg (INCL. WITH HL62BH)
- 15 JOINT FILLER
- 16 ASSEMBLY FOAM
- 17 DOWNPIPE THERMAL INSULATION
- 18 DOWNPIPE
- 19 FILL FREE SPACE WITH MINERAL WOOL
- 20 BITUMEN MEMBRANE,  $\phi$ 750 mm

NOTE:

FLAT-ROOF DRAIN HL62.1BH HEATED (230V, 10-30 WATTS) CAN BE USED.

ASSEMBLY INLET:  $\phi$ 220 MM, ALTERNATIVELY 240X360 MM

122111A