

WARM ROOF – GLUED SYSTEM, CLASSICAL STRUCTURE, WITHOUT MOISTURE STOP,
 CONCRETE SUPPORTING STRUCTURE, PLASTIC FOIL WATERPROOFING

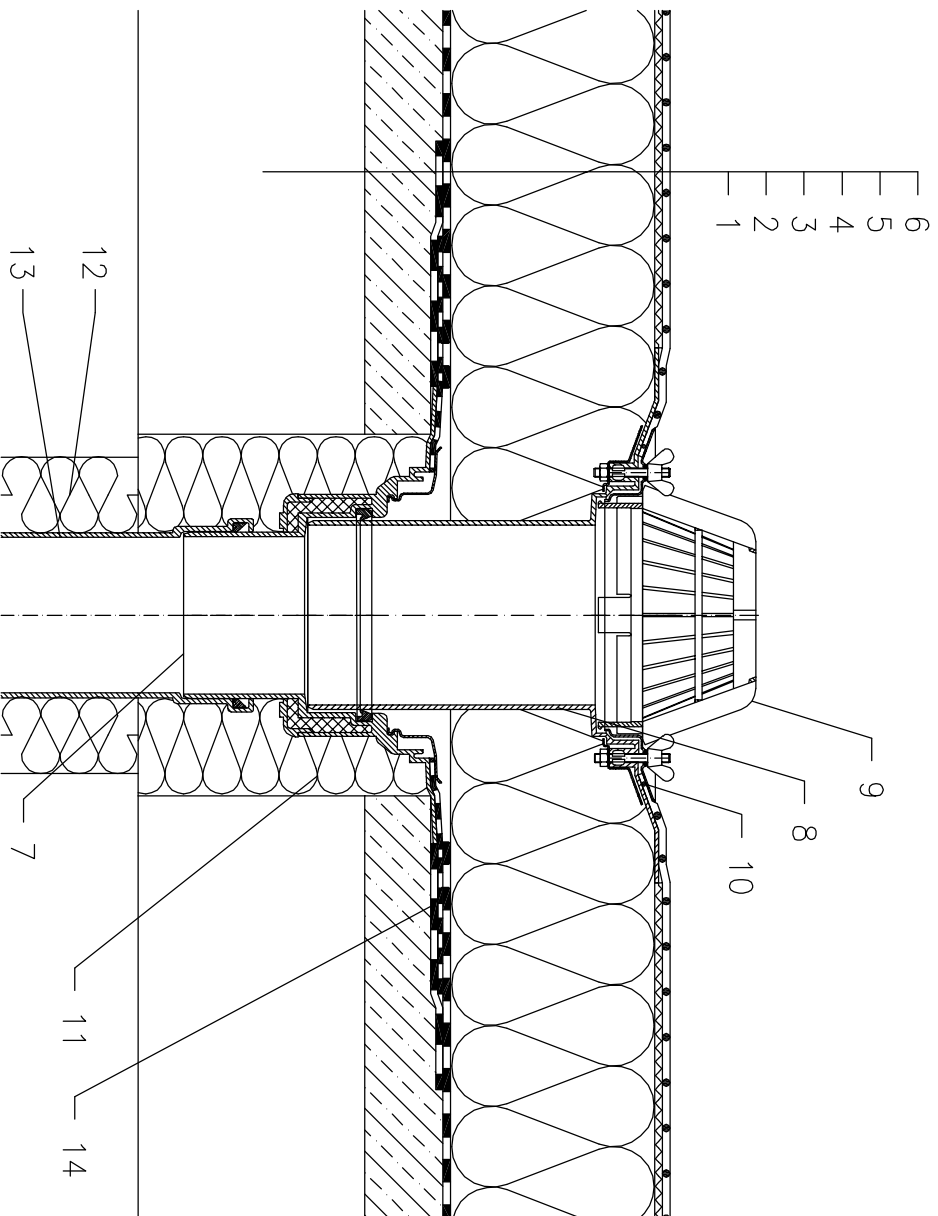

- 1 SUPPORT CONSTRUCTION
- 2 GRAVITY LAYER
- 3 DILATATION LAYER AND TEMPORARY SAFETY WATERPROOFING FROM BITUMEN SHEET
- 4 THERMAL INSULATION
- 5 DILATATION LAYER
- 6 PLASTIC FOIL WATERPROOFING NON-SOLID GLUED FLAT-ROOF DRAIN HL62H WITH INSULATED DRAIN BODY, WITH FACTORY WELDED BITUMEN MEMBRANE $\phi 500$ mm, THICKNESS 4 mm
- 7
- 8 EXTENSION HL65 WITH FLANGE, STAINLESS STEEL CLAMPING RING AND LIP SEAL
- 9 DOMED PLASTIC GRATE $\phi 180$ mm (INCL. WITH HL62H)
- 10 SEALING PACKING (SEE DETAIL-ACCESSORIES)
- 11 ASSEMBLY FOAM
- 12 DOWNPIPE THERMAL INSULATION
- 13 DOWNPIPE
- 14 BITUMEN MEMBRANE, $\phi 750$ mm

NOTE:

FLAT-ROOF DRAIN HL62.1H HEATED (230V, 10-30 WATTS) CAN BE USED.

ASSEMBLY INLET: $\phi 220$ MM, ALTERNATIVELY 240X360 MM