

WARM ROOF – GLUED SYSTEM, CLASSICAL STRUCTURE, WITHOUT MOISTURE STOP,  
 CONCRETE SUPPORTING STRUCTURE, BITUMEN SHEET WATERPROOFING

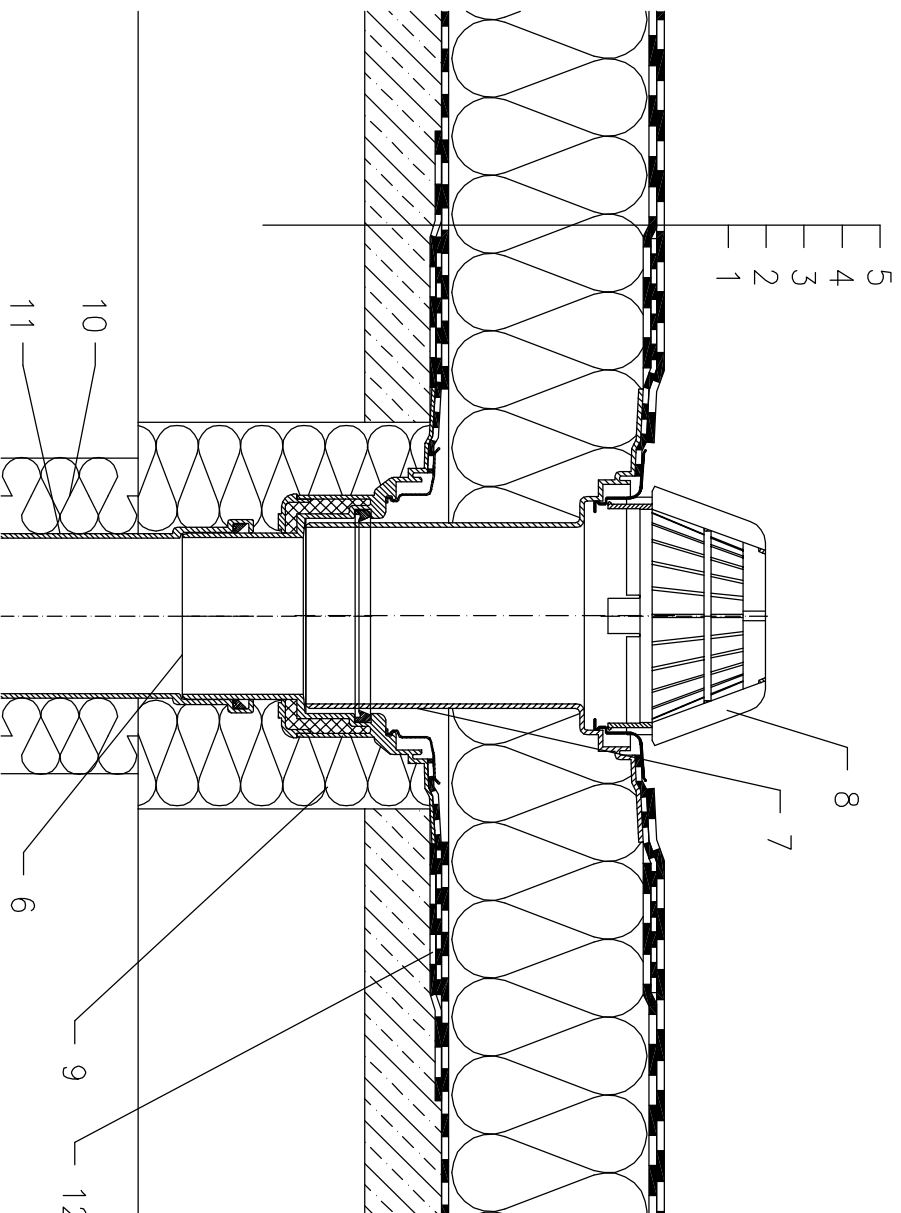

- 1 SUPPORT CONSTRUCTION
- 2 GRAVITY LAYER
- 3 DILATATION LAYER AND TEMPORARY SAFETY WATERPROOFING FROM BITUMEN SHEET
- 4 THERMAL INSULATION
- 5 BITUMEN SHEET WATERPROOFING GLUED
- 6 FLAT-ROOF DRAIN HL62H WITH INSULATED DRAIN BODY, WITH FACTORY WELDED BITUMEN MEMBRANE  $\phi 500$  mm, THICKNESS 4 mm
- 7 EXTENSION HL65H WITH FLANGE AND FACTORY WELDED BITUMEN MEMBRANE  $\phi 500$  mm, THICKNESS 4 mm
- 8 DOMED PLASTIC GRATE  $\phi 180$  mm (INCL. WITH HL62H) ASSEMBLY FOAM
- 9 ASSEMBLY FOAM
- 10 DOWNPIPE THERMAL INSULATION
- 11 DOWNPIPE
- 12 BITUMEN MEMBRANE,  $\phi 750$  mm

NOTE:

FLAT-ROOF DRAIN HL62.1H HEATED (230V, 10-30 WATTS) CAN BE USED.

ASSEMBLY INLET:  $\phi 220$  MM, ALTERNATIVELY 240X360 MM