

## ROOFS WITHOUT THERMAL INSULATION – INTENSIVE GRASSING, PLASTIC FOIL

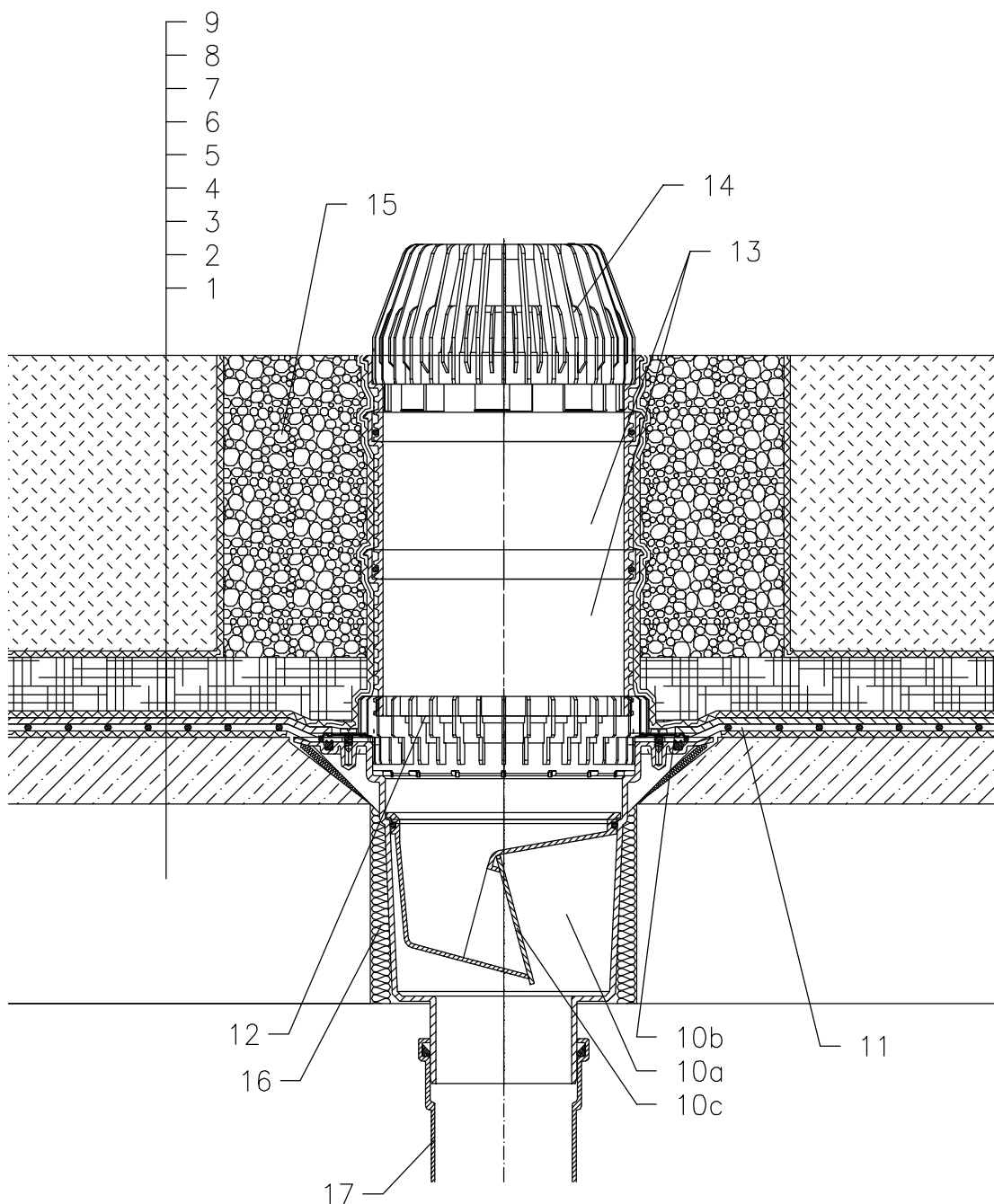

- 1 SUPPORT CONSTRUCTION
- 2 CONCRETE GRAVITY LAYER
- 3 SEPARATING LAYER
- 4 PLASTIC FOIL WATERPROOFING
- 5 DRAINAGE LAYER
- 6 FILTER LAYER
- 7 WATER ACCUMULATING LAYER
- 8 FILTER LAYER
- 9 VEGETATION LAYER (OVER 200mm)
- 10a DRAIN BODY HL616K WITH FLANGE
- 10b FROST-PROOF FLAP HL0606.3E
- 10c SEALING KIT HL86.0 – WITHOUT SHEETING,
- 11 PRE-CUT PART FOR SEALING COLLAR, SEE TOPIC "ATTACHEMENTS"
- 12 DRAINAGE RING HL190
- 13 EXTENSION HL620
- 14 LEAF STRAINER HL195
- 15 GRANULAR FILL
- 16 ASSEMBLY FOAM
- 17 DOWNPIPE

### NOTICE:

TO HEAT THE DRAIN, YOU MAY USE HEATING KIT HL609 WITH SELF-REGULATING HEAT SOURCE 36W/230V. (THE HEATING TAPE MUST BE WRAPPED AROUND THE DRAIN BODY BEFORE INSTALLATION).  
 RECOMMENDED BOREHOLE DIAMETER IS  $\varnothing 220\text{mm}$ , WITH HEATING KIT MIN.  $\varnothing 240\text{mm}$   
 DURING INSTALLATION TAKE CARE, THAT THE FLANGE POSITION IS ON THE LOWEST LEVEL OF DRAINAGE. WE RECOMMEND, TO SITE IT APPR. 1cm BELOW THE SCREED.  
 TO AVOID CONDENSATE WATER TAKE CARE OF THERMAL INSULATION ON THE CONSTRUCTION SITE.

112322Y