

ROOFS WITHOUT THERMAL INSULATION – TERRACE, PAVEMENT IN SUBBASE, PLASTIC FOIL

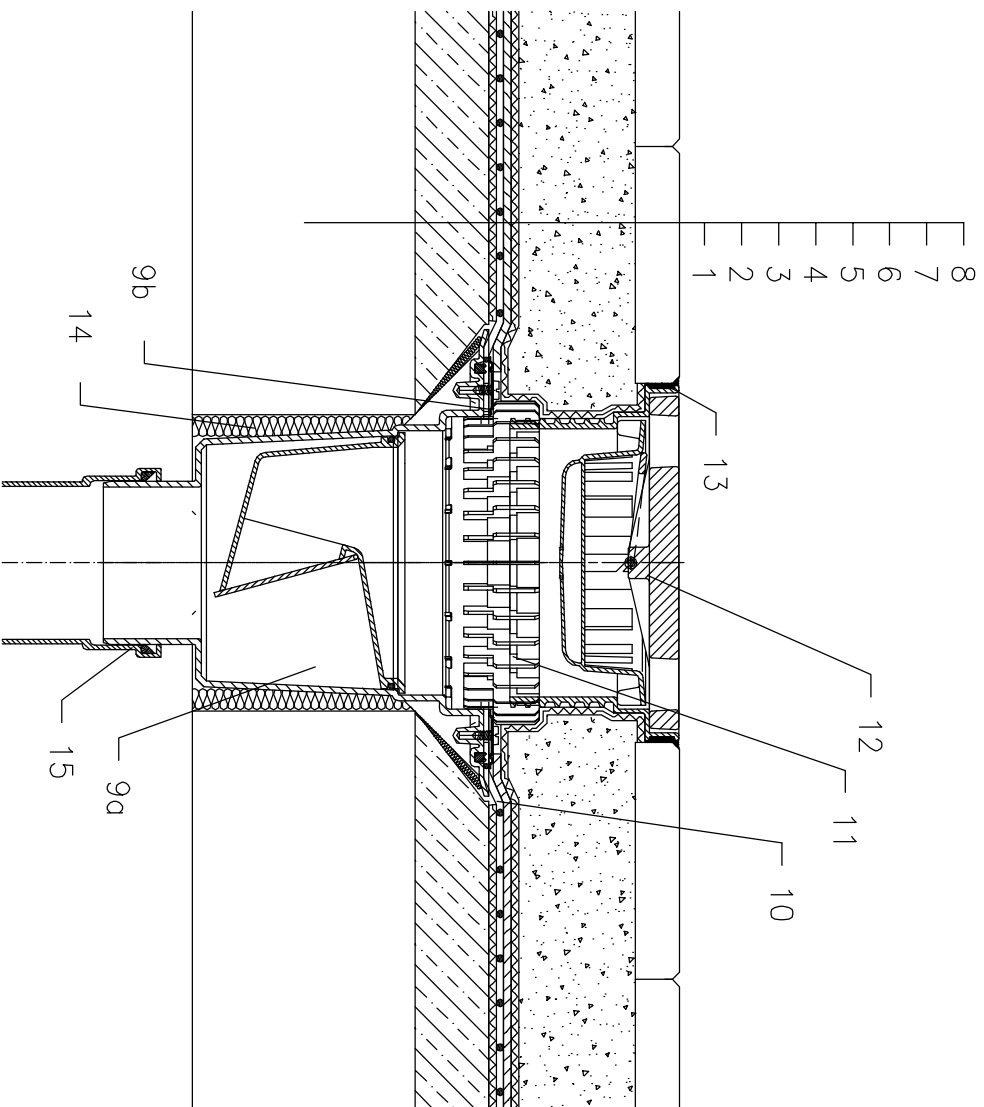

- 1 SUPPORT CONSTRUCTION
- 2 CONCRETE GRAVITY LAYER
- 3 SEPARATING AND DILATATION LAYER
- 4 PLASTIC FOIL WATERPROOFING
- 5 DRAINAGE LAYER
- 6 FILTER LAYER
- 7 SAND SUBBASE
- 8 PAVEMENT
- 9a TERRACE DRAIN HL616 WITH FROST-PROOF FLAP AND FLANGE
- 9b SEALING KIT HL86.0 – WITHOUT SHEETING,
- 10 PRE-CUT PART FOR SEALING COLLAR, SEE TOPIC "ATTACHEMENTS"
- 11 DRAINAGE RING HL190
- 12 EXTENSION WITH CAST IRON GRATE 226x226 mm AND PLASTIC FRAME 240x240 mm (INCLUDED IN HL616) alternative HL616S – WITH STAINLESS STEEL GRATE alternative HL616L – WITH PLASTIC GRATE
- 13 NON-HARDENING MASTIC
- 14 ASSEMBLY FOAM
- 15 DOWNPIPE

NOTICE:

TO HEAT THE DRAIN, YOU MAY USE HEATING KIT HL609 WITH SELF-REGULATING HEAT SOURCE 36W/230V. (THE HEATING TAPE MUST BE WRAPPED AROUND THE DRAIN BODY BEFORE INSTALLATION).

RECOMMENDED BOREHOLE DIAMETER IS $\phi 220\text{mm}$, WITH HEATING KIT MIN. $\phi 240\text{mm}$ DURING INSTALLATION TAKE CARE, THAT THE FLANGE POSITION IS ON THE LOWEST LEVEL OF DRAINAGE. WE RECOMMEND, TO SITE IT APPR. 1cm BELOW THE SCREED. TO AVOID CONDENSATE WATER TAKE CARE OF THERMAL INSULATION ON THE CONSTRUCTION SITE.