

NON-INSULATED – GLUED SYSTEM, PLASTIC FOIL WATERPROOFING

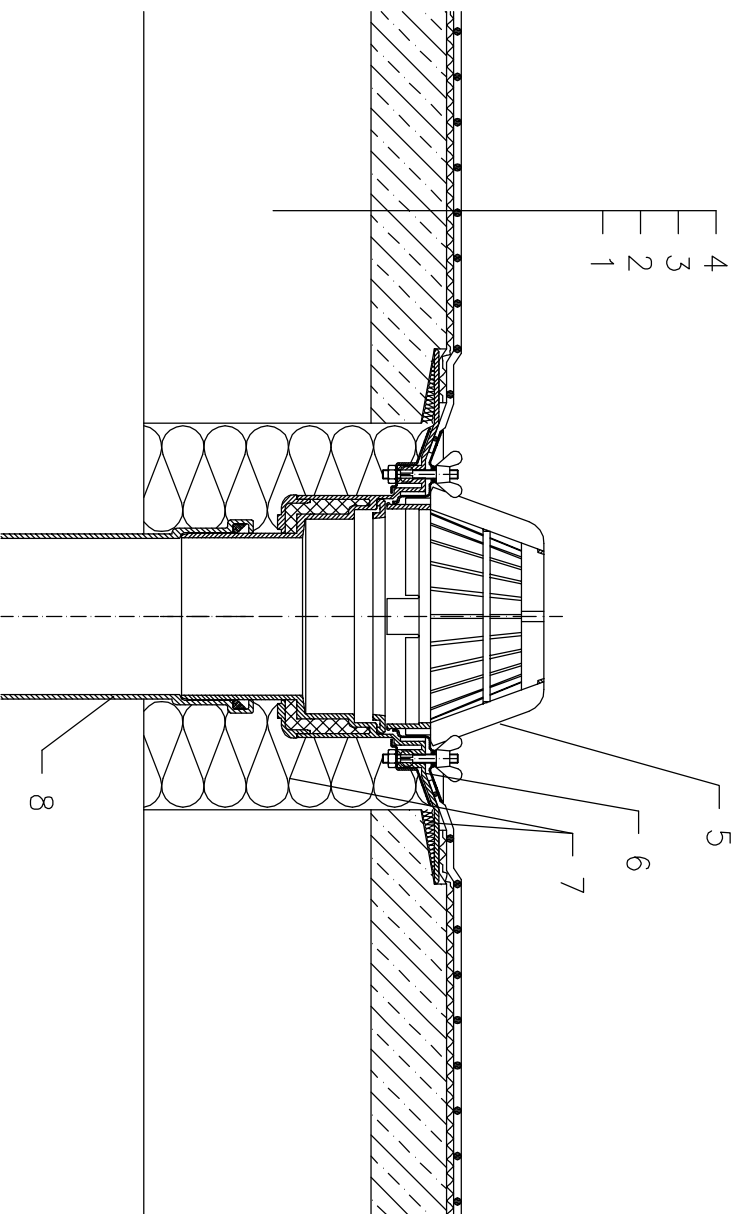

- 1 SUPPORT CONSTRUCTION
- 2 GRAVITY LAYER
- 3 DILATATION LAYER
- 4 PLASTIC FOIL WATERPROOFING NON-SOLID GLUED
- 5 FLAT-ROOF DRAIN HL62 WITH INSULATED DRAIN BODY, FLANGE AND STAINLESS STEEL CLAMPING RING, DOMED PLASTIC GRATE $\phi 180$ mm
- 6 SEALING PACKING (SEE DETAIL-ACCESSORIES)
- 7 ASSEMBLY FOAM
- 8 DOWNPIPE

NOTE:

FLAT-ROOF DRAIN HL62.1 HEATED (230V, 10-30 WATTS) CAN BE USED.

ASSEMBLY INLET: $\phi 220$ MM, ALTERNATIVELY 240X360 MM