

NON-INSULATED – LOADED SYSTEM, BITUMEN SHEET WATERPROOFING

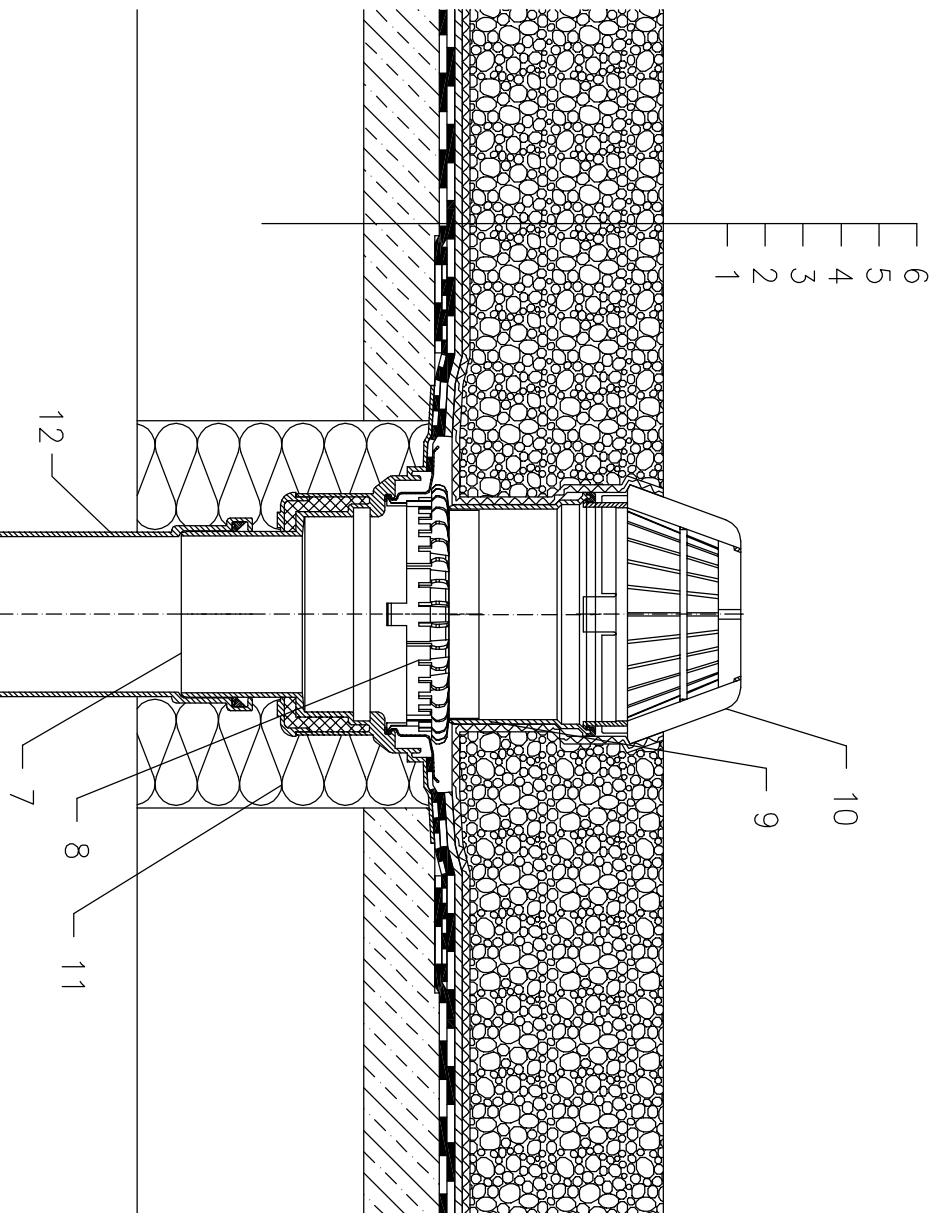

- 1 SUPPORT CONSTRUCTION
- 2 GRAVELLY LAYER
- 3 BITUMEN SHEET WATERPROOFING NON-SOLID GLUED OR LAID LOOSE
- 4 DRAINAGE LAYER
- 5 FILTER LAYER
- 6 STABILIZING LAYER
- 7 FLAT-ROOF DRAIN HL62H WITH INSULATED DRAIN BOX WITH FACTORY WELDED BITUMEN MEMBRANE \varnothing 500 mm THICKNESS 4 mm
- 8 GRAVEL GUARD HL160
- 9 EXTENSION HL350
- 10 DOMED PLASTIC GRATE \varnothing 180 mm (INCL. WITH HL62H)
- 11 ASSEMBLY FOAM
- 12 DOWNPIPE

NOTE:

FLAT-ROOF DRAIN HL62.1H HEATED (230V, 10-30 WATTS) CAN BE USED.

ASSEMBLY INLET: \varnothing 220 MM, ALTERNATIVELY 240X360 MM